

An Official Digital Publication of the New York State Art Teachers Association

Volume 47 • No. 3, Winter 2018

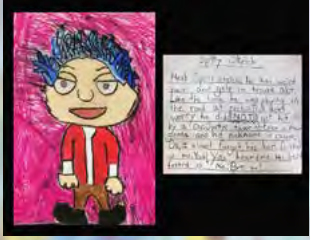

A Matter of Choice: Examining Student Choice in the Art Classroom

Inside This Issue

| | |
|---|-------|
| President's Message..... | 3 |
| About the News..... | 4 |
| Letter from the Editor | 5 |
| NYSATA News Receives 2018 NAEA Newsletter Award | 5 |
| The Collaborative History Mural Project | 6 |
| What's New in Media Art Education..... | 9 |
| The Bookmark: Social Media as Book Study! | 11 |
| Pre-service Perspective: Reflecting on Student Choice | 13 |
| Technology: The Connected Classroom..... | 13 |
| Using Choice Board Organizers in the Art Room | 15 |
| Cultivating Curiosity: Choice in the Art Room..... | 21 |
| Guest Essay: What College Never Told You | 25 |
| NYSATA Working for You: Program Updates | 28 |
| Student Scholarship Opportunities: Recognizing Excellence | 32 |
| Call for Award Nominations | 33 |
| Call for 2018 Conference Workshop Proposals | 35 |
| NYSATA 2017 Art Educator of the Year Acceptance Speech..... | 38 |
| NYSATA 2017 Conference Highlights | 40-50 |
| BOT Information..... | 51 |

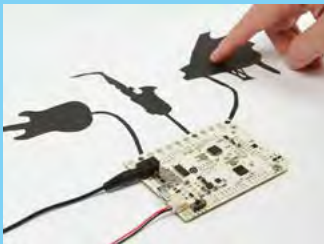

Executive EditorMartin Merchant
 Layout & Design EditorPat Groves
 Photos: Marty Merchant, Robert Wood, Phyllis Brown. Individual contributors provided images for their articles.

Arp, Art & Institution

Lesson Plan for Grades 3-12 and Special Education

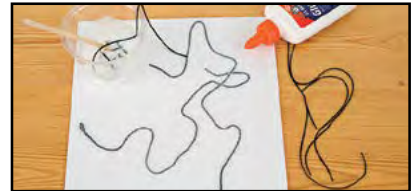

Step 1: Dip string in a mixture of glue and water and allow it to fall on the board in a wandering line.

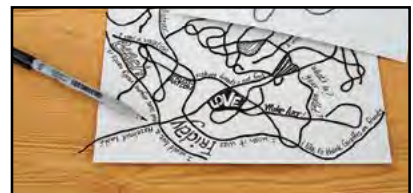

Step 2: Use a “stream of consciousness” approach to add words and thoughts.

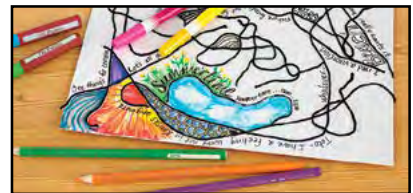

Step 3: Fill spaces with colors, textures, designs, and small illustrations using a variety of media.

An intuitive approach to art-making!

Randomness and chance are the central themes of this drawing and writing exercise inspired by the abstract art of Jean (Hans) Arp.

DickBlick.com/lessonplans/arp-art-and-intuition

FREE lesson plans and video workshops at DickBlick.com/lessonplans. For students of all ages!



BLICK®

800•447•8192 DickBlick.com

Request a
FREE catalog!

DickBlick.com/requests/bigbook



President's Message from Sharon Ciccone



A few years ago, I wrote my first article for the *NYSATA News* reflecting on my first year implementing choice-based art education in my classroom. At the time, I knew very few teachers that had embraced the idea of teaching for artistic behaviors or providing a classroom environment where students had more autonomy over their own learning and artistic creations. So much has changed these last two years, and I have made more and more connections with teachers interested in the idea of choice and how that could be adapted for their own students and art programs.

My own journey began with two simple questions: "What am I teaching my students about art?" and "What am I teaching them about being an artist?" I remember once after hanging a display and stepping back to look at it, noticing that although each work was intrinsically unique in imagery and meaning, there was a "sameness" to the work. Most of the work followed the same step by step structure and used the same art media. I was creating a "no-fail product". As long as my students followed the steps I had outlined, they would be successful. This realization was the epiphany I needed.

The methods for providing choice to my students have changed from year to year. Choice can have many meanings and different manifestations. There is no one way of providing choice. The new New York State Learning Standards for the Arts have given us all the opportunity to pause and reflect on our methods of instruction and how we can create a curriculum that will provide students an opportunity to authentically demonstrate their understanding, knowledge, and skills as art reflected in the Anchor Standards, Enduring Understandings, Process Components and the Grade Level Performance Indicators. Taking time to incorporate independent and collaborative ways of working, providing challenges with multiple solutions that directly engage students in making critical decisions, and encouraging persistence in overcoming creative and technical obstacles, is an important part of implementing the Standards.

Choice-based art education is often linked to the eight dispositions of the Studio Habits of Mind ("Studio Habits of Mind from Studio Thinking: The Real Benefits of Visual Arts Education", Hetland, Winner, et al, Teachers College Press, 2007). Personally, the Studio Habits of Mind provided me a vocabulary and structure for thinking about learning based on individual choice. Because these are dispositions for learning, they cross all curricular boundaries. I use these to guide my students through artistic challenges, but they have also been a source for helping me work through obstacles in art education. I recently shared these dispositions and some of the questions that I ask myself when dealing with educational issues during

my NYSATA State Conference workshop, "Leading the Way", this past November.

- **Reflect:** What is happening within my classroom, district, community, or state that is directly impacting the quality of art education for my students? Is this an issue that I have created or was it created externally? What is the result?
- **Envision:** What does the ideal art education experience look like within the classroom, district, community, or state?
- **Observe:** What have I specifically observed that impacts the quality of art education?
- **Stretch and Explore:** What are some mistakes I have made in the past when it comes to this issue? What is within my control and what requires additional help? What are some alternative solutions that I should explore?
- **Understand Art Worlds:** What is the history behind this issue? How did this issue develop over time? How are other artists, teachers, districts, or institutions dealing with this issue?
- **Develop Craft:** What are the resources, materials, and educational tools that I need to support my efforts?
- **Express:** What is the message I need to convey to stakeholders?
- **Engage and Persist:** What are the steps I will need to take in order to begin tackling this issue? What/who can I use as support when I am stuck and need to move forward?
- **Reflect:** Am I seeing results? What are some of the small victories? What is not working? Why? What is getting in the way of my goal? What needs to be adjusted? Where can I find more help?

This process is cyclical and any paradigm shift in education requires gaining support of the stakeholders. Students are usually an easy sell. Getting districts on board, however, isn't quite as easy. Great strides can be made once you compile research examples that support your goals, have direct correlations to the mission of your school, align with the district-created curriculum, and provide examples of teaching methods that use inquiry and multiple perspective thinking.

This newsletter contains articles that will explore the role of choice in the art classroom and the role choice plays in fostering creative thinking skills. Every day we are bombarded with choices; we have choices in attitudes, actions, and experiences. We judge the merits of our options and select those that are meaningful, align with our goals, and are most likely to reach our desired outcomes. What is the role of choice in your own classroom?

Sharon Ciccone, NYSATA President

About the News

The **NYSATA News** publishes official announcements for NYSATA as well as commentary and research on topics that are important to art educators. The opinions expressed in editorials and articles are those of the authors and do not represent NYSATA policies. The **NYSATA News** encourages an exchange of ideas, and invites submission of news or articles for publication. To submit news or articles, please contact Editor, Marty Merchant at nysatanews@nysata.org. Advertising inquiries should be sent to Pat Groves at phgroves@aol.com.

Inquiries about receiving the **NYSATA News** should be directed to the Membership Chair Terri Konu, 9200 Sixty Road, Phoenix, New York 13135, (315) 695-2500, e-mail: tkonu@nysata.org. To change your address, please log into the NYSATA website and update your own address and contact info in your profile.

Photo Submissions: Graphics should be in jpeg, tiff, or pdf format, 150ppi. Photographs and print-ready art are always welcome in jpeg or pdf format. For purposes of accurate identification and acknowledgement, photos sent to the **NYSATA News** must be accompanied by the following information: your name, phone number, and e-mail; name and address of photographer; and first and last names of persons in the photo (in order from left to right, front to back). If art work is presented, the artist's name, school name, teacher name and NYSATA Region must be included. Additionally, any photos that depict students under 18 must have parental permission to be printed.

An award winning publication, The **NYSATA News** has been named winner of the National Art Education Association State Newsletter Award Category 3 in 2011, 2012, 2015, 2016, and 2017. Chosen by a panel of visual arts educators from across the nation, this award honors art education publications that demonstrate outstanding achievement and exemplary contributions to the field of art education.

Members of the 2017-2018 Contributors Board

Executive Editor..... Martin Merchant
Layout and Design EditorPat Groves
Proofreader..... Jo Merchant
Features Editor, Photographer Martin Merchant
AdvocacyDr. Susan Lane
Technology: The Connected Classroom Cory Merchant
Pre-service Student News Chloe Dudla, Erin Maloney
The Book Mark, Book and Media Reviews
.....Cynthia Wells
NYSCEA CorrespondentDr. Patricia Wheelhouse
NYSED Updates Leslie Yolen

NYSATA Members interested in serving on this board or contributing articles are encouraged to contact Martin Merchant at nysatanews@nysata.org

Digital publication by AGLAIA SOFTWARE/ePageView
<http://www.aglaiasoftware.com/>
5000 Parkway Calabasas, Suite 300, Calabasas, CA 91302



NYSATA

Proudly Presents...



36th Olympics of the Visual Arts

Saratoga City Center

Saratoga Springs, New York

Wednesday April 25, 2018

Or more information go to <https://nysata.memberclicks.net/olympics-of-the-visual-arts>



A Matter of Choice

I want to thank our contributors for their hard work over the December holidays, the start of a new year and beginning new semester in the classroom. Our association brings together so much talent and collegial support; these writers have gone extra miles to share their experiences and observations about choice in their classrooms, along with the day-to-day practice of our profession.

Giving students choices is a basic instructional commitment in the art classroom. The new State Art Standards contain over 40 essential questions to help us pursue these newly articulated learning goals – questions that have traditional answers and questions that allow students to invent, explore, and understand their own answers. This issue is led by the insightful observations of NYSATA President Sharon Ciccone, as she reflects on her own journey to providing choices to her elementary students. She remarks on the rich and unpredictable environment of discovery for herself and her students, and relates how that journey has supported her as she advocates for the Visual and Media Arts. Julie Gratien follows with wonderful narrative about her exploration of choice boards in her art classroom. Dr. Ann Holt, Dr. Cindy McGuire and college senior Samantha Barone share the innovative lessons they developed in a service-learning project in a far distant land. Amy Mottola shares her

perspectives on what value a wide array of choice-based learning segments have brought to her students.

Emily Maloney and Chloe Dudla give their beginner's view on classroom and personal challenges, while Courtney Yacuzzo offers her insights on art room startup strategies. You will find many different communities of learners in these articles, and be inspired by the inventive persistence of the writers.

We know that teaching artistic behaviors – to echo the title of that influential book – brings to children a dimension of learning experience that cannot be fully implemented by other disciplines. As art educators, we encourage and offer choices in our classrooms so students can solve the challenge of expressing themselves individually with visual language, materials and processes that best communicate their personal idea. We try to make choices in our own practice that allow us to operate at our highest potential. This issue of the *NYSATA News* may spark some changes in your thinking, and will certainly evoke feelings of pride and wonder with our colleagues.

Marty Merchant

The NYSATA News Receives NAEA Award

The *NYSATA News* is once again the recipient of the National Art Education Association Newsletter Award for Category III. The award will be presented during the 2018 NAEA National Convention in Seattle, Washington. This is the sixth time the *NYSATA News* has been chosen to receive this award since 2012. Congratulations to Editor Marty Merchant, Layout and Design Editor Pat Groves, all of the contributors, and the *NYSATA News* Contributors Board for their dedication and commitment to making the “*NYSATA News*” a quality publication.



Handwork being done during the authors' workshop on Interactive Art at the 2018 NYSATA Conference, showing paper cutouts with LED and touch board audio connections.

The Collaborative History Mural Project: uncovering hidden histories with sound and light in an interactive STEAM and Humanities project

Cindy Maguire, Ann Holt, Samantha Barone

These writers shared their mural project in a workshop at the November conference in Binghamton to general acclaim. By participating in a distant project through a service group in a war-beaten part of the world, they inspire us with their dedication, and by integrating technology and contemporary art practice with interdisciplinary connections, they encourage us to embrace change and innovation.

This past NYSATA conference, we (two art education professors and a senior art education major at Adelphi University in Garden City Long Island) presented a combined STEAM and Humanities workshop based on a project we did as part of an undergraduate course in art and design called Exploring the Arts. The Collaborative History Mural project, inspired by Spiral Workshop Theme Curriculum¹, involved the creation of a large-scale interactive wall mural using light and sound that highlighted lesser-known historical narratives of US history via researching physical and digital archives. This article takes readers through a process which combines a STEAM and Humanities curriculum by incorporating conductive interactivity and microprocessors into artwork. We used Bare Conductive Touch Boards for sound² and TinyLily³ LilyPads for LED light.

STE(A)M Learning: Science, Technology, Engineering, ART, Math

This project offers possibilities for art and design teachers to collaborate with teachers of technology, science, history and/or social studies in their respective schools. STEM learning, which often favors left-brain convergent thinking – one best answer, is brought together with art and design learning, fostering right-brain divergent thinking – many ‘right’ answers. Students have an opportunity to learn about the fundamentals of electricity, circuits, circuit diagrams, and microprocessors while simultaneously building interactivity

into a work of art. The materials we used are accessible for beginners and learning across the STEM concepts can be scaffolded as needed.

Background of the project

In 2017 we traveled to Kosovo with art education students from NYU as part of ArtsAction Group, an international community-based collective committed to supporting arts initiatives with children in conflict-affected environments. We facilitated a project, *Utopia/Dystopia*⁴, where youth created a series of large scale graphite drawings around their notions of utopia and dystopia. Using graphite as the conductive material, specific areas in each drawing were wired for sounds related to the drawings. These points were then activated by a viewer's touch, which in turn expanded upon the meaning of the artwork. The Utopia/Dystopia STEAM and interactive art and design project builds upon an established partnership between ArtsAction Group and the Centre for Creative Education at Fellbach-Haus in Suhareka, Kosovo. Digital media is recognized as potential economic growth lever for the youth and young adults in this community. ArtsAction Group explores these possibilities via project-based learning at the center as well as through other partnerships with children and youth in the USA.

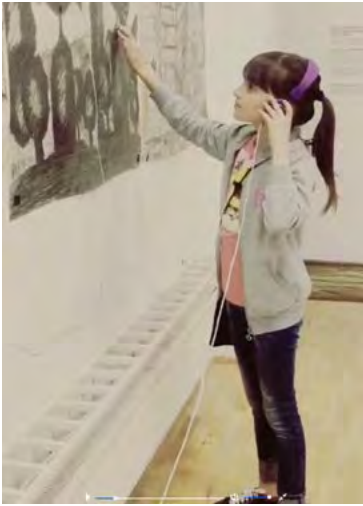

Still image from a video by Utopia/Dystopia teaching artists Sasha Spare and Shannon Kopunek.

Using archives as starting points for bigger questions

At the end of this article, we offer a list of possible starting points to consider for students to do research and get inspiration. In this lesson, the archives served as a starting point for the research and art making. In the Adelphi Special Collections Library, we led students towards thinking about how history is mediated – what we know is largely based on what we gather and make accessible. Questions discussed in this lesson were: Who and what groups are being left out?

Who decides whose narratives are deemed worth remembering in histories and why? Whose interests are being served by leaving out the messiness of political turmoil, cultural conflict, racism, and class discrimination?

Making links to Contemporary Art

Silhouette cutting originated in Europe in the early 1700s. Associated with the royal class, this form of artmaking was taken up by the wealthy class in the United States in the 1800s. Sticking to the theme of lesser known historical narratives, we explored artists that use symbolism in their work to disrupt historical narratives. Contemporary artist, Kara Walker, uses the traditional silhouette to convey issues around gender, race, sexuality, and violence during the antebellum period in the United States. The wall-size installations of silhouettes draw the viewer in, and in some cases use the audience's own shadow to help activate the nightmarish stories that make up our collective past, turning the original use of the silhouette on its head.

Our Process: Artist as Researcher

Art and Design education students at Adelphi University learn the importance of research as part of the arts learning process to build understanding around big ideas. The Collaborative History Mural project was research driven and this process played a key role from concept to the final product.

After viewing Walker's artwork, we went to the to peruse materials selected by the archivists representing historical narratives on the margins. Topics ranged from slavery, women in the military and NASA, to ancient swords. One student selected the topic of gender norms in the 16th century. Through her research she found that during this time men would wear high heels as an expression of their social standing. When comparing these findings against men's fashions today, the question of how masculinity is expressed through fashion came to the fore. She created a large-scale cut out of a hyper-masculine bodybuilder recontextualized by adding tight pants and high heels. A cat call whistle, typically directed by a man, or group of men, towards a woman or group of women was added via a sound file. The juxtaposition

of the hybrid male/female figure with the cat call sound adds an emphasis to the social structure, standards and irony of today's social norms when it comes to gender and fashion.

Interactivity in Art: Expanding on Meaning and Engagement

Interactivity in artmaking, a genre with historical roots in the Happenings of the 1960s, is a growing presence in contemporary art practices. Using digital technologies, artists can make art where meaning is co-created through the participation of the audience. The incorporation of sound and light into an artwork can be a powerful way to extend this meaning. Imagine your artwork "talking to you" or reacting to your touch. For students, the act of choosing a sound, or number of sounds, activates the senses, demands students to think about how sound (heard by oneself or with other viewers) can become a form of play, create a focal point, and add another dimension of meaning.

Thinking through Sound and Light

Choosing the sound element for our work was informed by the content. But other aesthetic considerations came to the fore when creating the sound file. How loud is it? For how long does it continue? Is it pitched? If it is pitched, how high is it? How low is it? How far away is it? Is it moving? In which direction? How fast? Is it changing? How is it changing? What is changing? And, if there is more than one sound, how do the sounds work together to create meaning? The same is true of

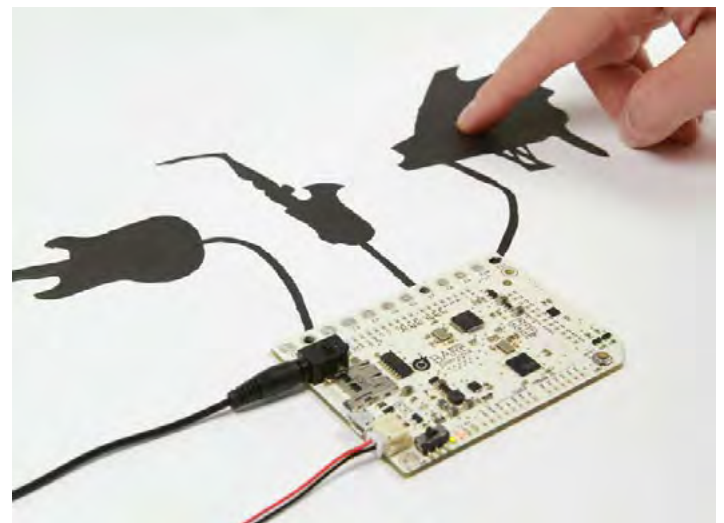

The touch board

the light component. How will the light function? Will it be steady? Will it pulse like a heartbeat? Slow or fade? How do lights help to create focal points and convey meaning?

How to use the Bare Conductive Touch Board and LilyTiny

Our NYSATA workshop led teachers through the steps on how to assign and add sound to a small, cut out symbol they created in the workshop. They also learned how to add a light component using the LilyTiny and an LED light. The touch board adds the sound interactivity. It is a microcontroller-based platform that gives the artist the ability to turn almost any material or surface into a sensor. The process involves uploading Mp3 files off the computer onto an SD card which is then inserted into the touch board. Plug in your speakers and wire the touch board to the areas of the artwork that you want to be touch-sensitive using any conductive material.

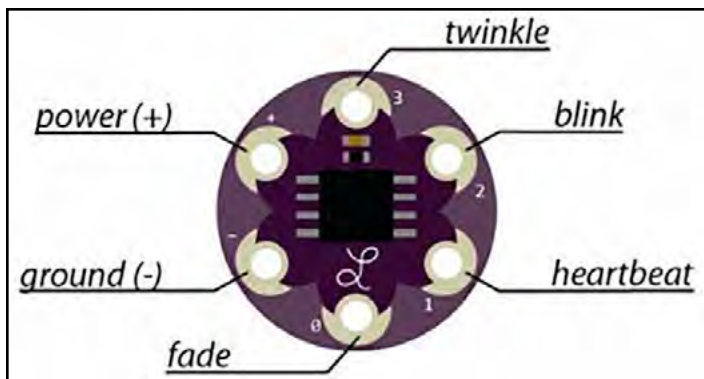

LilyTiny: A microcontroller is like a miniature computer. It acts like a 'brain' of a circuit. Each LilyTiny contains a microcontroller that has been pre-loaded with a program. The program can control the behavior of connected LED lights causing them to blink, fade, twinkle, or pulse like a heartbeat.

Tutorials are available online which make it easy to understand and incorporate conductors into artmaking.

The LilyTiny is a basic, small microcontroller that lets you add different light features to art, textiles, and more. You pick the function that you want your light to do and follow the positive and negative traces between the battery and the LED light. Tutorials available online will open your eyes to a world of possibility in using light as a art medium.

Putting it All Together!

Construction of final piece is also a consideration in our pedagogy. Students think about their audience, the composition of the whole, the placement of the artist statements and the potential meanings generated by juxtaposition, sound, light, and how the conductive element becomes part of the overall aesthetic experience. Conductive elements include, wire, graphite (pencil), copper tape, conductive thread (Here is a STEM question: What materials make good conductors of electricity?)

STEAM Resources:

Bare Conductive: <https://www.bareconductive.com/>
 STEAM in Action! <http://www.steaminaction.com/> - projects, artists, rationale for STEAM, links to resources & materials

Historical Materials for research:

Texts for Hidden History: *Lies My Teachers Told Me* by James Loewen

Or see James Loewen "Debunking History" at <http://www.ushistory.org/us/historians/loewen.asp>

Zinn Project <http://zinnedproject.org/>

Visit your local historical society or ask them to come to you. Also, the library and/or archives (email archivist to make an appointment on your own)

Through a google search, look for your own digital resources

See: Visual History Archive: <https://sfi.usc.edu/vha>

See: American Memory Project: <https://memory.loc.gov/ammem/index.html> and Many More!

Finding Sounds:

<https://freesound.org/>, <https://www.zapsplat.com/>, <http://www.noiseforfun.com/>, <http://soundbible.com/>, Record your own!

Resources

1. The Collaborative History Mural project, inspired by Spiral Workshop Theme Curriculum https://naea.digication.com/Spiral/Spiral_Workshop_Theme_Groups/



Mural: Each silhouette on the mural includes two focal points. One indicated by a beating LED light, the other by a small point of color wired for sound. In the center of the chain between the manacled hands, as an example, is a small, coiled wire. When touched, this activates a recording of an actor reading aloud a quote on women's health rights by Margaret Sanger, a Feminist activist an educator. This quote plays until the viewer moves on to activate another symbol's sound.

2. We used this basic touch board from Bare Conductive for our sensors <https://www.bareconductive.com/shop/touch-board/> PDF downloads and video tutorials for constructing with the touch board <https://www.bareconductive.com/make/resource-guide/>

3. The LilyTiny LED boards we used for our project can be found at Sparkfun <https://www.sparkfun.com/products/10899> Tutorials are available that survey the wide range of possibilities for using light <https://www.sparkfun.com/tutorials/390>

4. The ArtsAction Group *Utopia/Distopia* program can be found at <https://www.artsaction.org/kosovo.html>



Ann Holt, Ph.D. serves as a Visiting Professor at Adelphi University and Pratt Institute. Ann is interested in issues of marginalized historic narratives as well as access to knowledge and understanding of the past. Her research encompasses interests in archives and marginalized histories of art education.



Cindy Maguire, Ph.D. is Associate Professor and Director of the BFA Art & Design Education Program and the Levermore Global Scholars Program at Adelphi University. She also Co-Directs ArtsAction Group, an international community-based collective committed to facilitating arts initiatives with children and youth in conflict-affected environments



Samantha Barone is a Senior at Adelphi University majoring in Art & Design education. She has been working with technology and art throughout her time at Adelphi, finding it to be beneficial to the classroom environment and a great tool to use in the classroom.



What's New in Media Art Education?

Robert Wood

The National Coalition for Core Arts Standards has identified Media Arts as a fifth discipline after extensive feedback from the field. Media Arts draws from all the Arts disciplines and the line between Media Arts and the Visual Arts is often a fluid one. Many states, including New York, have followed the model created by the National Core Arts Standards and included Media Arts as a discipline with its own set of standards.

In September of 2017, following Regents approval of the newly completed New York State Learning Standards for the Arts, the NYSATA Board of Trustees approved the formation of the NYSATA Media Arts Committee. The goal of the new committee is to address the emerging needs of Arts educators to address roll out, implementation, and practice of the NYS Media Arts Standards.

Throughout the state, roll out to educators has begun. At the NYSATA 2017 Conference in Binghamton, a portion of the Pre-Conference, and two workshops (affectionately called "Standards Slams"), were dedicated to the new Visual and Media Arts Standards. An additional workshop, specific to contemporary practice in Media Arts, was led by Dr. Susan Lane. The Pre-Conference and workshops focused on: presentation, exercises, and discussions, allowing participants to examine how present curricula may change to address new anchor standards. Those gatherings also examined enduring understandings, essential questions, along with how collaboration and student choice may be built into lessons; and how this process of change can be shared with others.

Questions have arisen regarding pre-existing curricula in schools utilizing the tools of new media. Schools should welcome the opportunity to examine existing Media syllabi and curricula. In general, schools will need to address the following:

- What is the certification of the teacher teaching the course?

- What standards are being addressed in the curricula?
- Media Arts courses, following the NYS Media Arts Standards, would qualify for an Art credit and therefore be taught by a certified Visual Arts educator.

As the roll out of the new Media Arts Standards continue, the first meeting of the Curriculum Advisory Panel met at the State Education Department in Albany in November. Consisting of Art educators in each of the five Arts disciplines, panelists including three media arts writers, began preliminary work. Serving in an advisory role, the CAP will provide written and verbal feedback to the Department on suggested resources, policies, assessment, and implementation strategies.

NYSATA looks forward to providing ongoing updates as the implementation of the Media Arts Standards continues in New York State.



Robert Wood is the NYSATA Media Arts Committee Chair, NYSED Media Arts Writing Chair, Curriculum Advisory Panelist, and the NYSATA Immediate Past President. He is an Art Educator at Roy C. Ketcham High School, Wappingers Central School District in Wappingers Falls, NY.

The National Coalition for Core Arts Standards has identified Media Arts as a fifth discipline after extensive feedback from the field. Media Arts draws from all the Arts disciplines and the line between Media Arts and the Visual Arts is often a fluid one.



Illustration by Sherri Hamilton, director of the Nazareth College Visual Communication Design program

With one of the top-ranked art education programs in New York State, Nazareth College inspires and prepares graduates to be teachers, researchers, and artists. Learn more: go.naz.edu/art

ART EDUCATION | ART HISTORY | STUDIO ART | VISUAL COMMUNICATION DESIGN

NAZARETH COLLEGE

4245 East Avenue, Rochester, NY 14618 ▪ admissions@naz.edu ▪ 585-389-2860



Social Media as Book Study!

Last summer Region 3 offered a book study to their membership by using a Facebook group. We thought it was a good way to keep in touch within our large region and offer something different. It met with success, and soon Region 1 joined for our second book. There are many different ways to use this idea. We selected novels about artists based on fact. Books on current art education themes and pedagogy, biographies of artists, graphic novels, and student texts are just a few other possibilities.

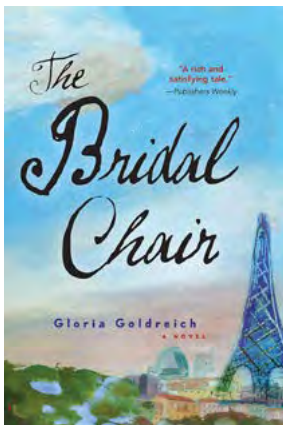

The first book selected was *The Bridal Chair* by Gloria Goldreich

This is a book about art history, WWII, social mores with a focus on how Marc Chagall's life and painting affected his family through the eyes of his daughter, Ida.

Initial posts were sent out by moderator Heather McCutcheon once a week with a deadline for responses in seven days. Below are some examples.

Post:

Is it appropriate for an adult daughter to pose in the nude regularly for her father? Are there differences in how the European culture looks at nudity as compared to America?

Responses:

I've mull'd this over since reading it. I thought about it when my daughter was looking through an Ancient History book at the dentist and kept asking why everyone was naked. :) I kept saying that they didn't see it as a bad thing, artists found beauty in the human body. So as uncomfortable as this notion makes me feel, nor would I ever be able to do this to my children, I think he was studying the beauty of the figure with an accessible subject.

Chagall was a narcissist who believed he was always right and the greatest artist. His painting his own child was part of his artistic ego because he considered her a beautiful subject to paint.

Post:

What was the significance of Chagall's paintings with the

Jewish themes? What was his fascination with Christian symbols in his crucifixion paintings? How did religion influence Chagall's paintings and his life?

Responses:

Yes, it is interesting how he portrayed different biblical stories in his art. I read a few articles and it was suggesting that with his crucifixion paintings, he may have been showing that Christ was a Jewish man and also making a connection with Christ's suffering on the cross and the Jewish people's suffering under the Nazis.

I wondered if he did it to coax his ego. The fact that he painted both Christian and Jewish themes made me think that he felt he was all-inclusive . . . like he knew everything. I couldn't get away from his arrogance. It reminded me so much of Picasso's story.

Post:

Let's take a minute to look at this painting. It was painted here in the ADK [Adirondacks] by Chagall! Cynthia Wells, can you help me out with the name again



On the Road to Cranberry Lake, 1944

Response:

The Road or Way to Cranberry Lake as translated by my brother, a French teacher! It blew my mind that Chagall spent time at Cranberry Lake and that his wife died in Tupper Lake. I plan on doing some research when I get to camp in August!



Our second book was *Sunflowers* by Sheramy Bundrick. HarperCollins

This novel based on historical research depicts the last two years of Van Gogh's life. The book is narrated by a young prostitute he met in Arles in 1888 who falls in love with Vincent. Throughout the book there is a connection between brilliance and madness, and creativity and reality.

You definitely saw hints of his illness when he didn't take care of himself during the storm. He blamed it on painting and mentioned how it had happened before.

Post:

"Working is the only thing that does me real good," Vincent tells Rachel while he is in the asylum at Saint-Remy, when she worries he works too hard on his paintings." Do you agree? Why is Vincent so driven to create, even when he is most ill?

Responses:

I absolutely agree. So often, people tell me to slow down . . . take some time off. I almost feel like idle time invites the demons in. If I have too much time on my hands, I find myself slipping into a depression. Work keeps me focused, busy and happy.

I think we as artists, go to a particular "happy place" when we create. It's what we do. I tried giving up photography and started cooking all the time. I needed to make something to be happy! Vincent NEEDED to paint.

I agree. I know when I am working on some form of art I get into a zone – time doesn't matter and I do not want to be disturbed. Artists need to create, Vincent HAD and NEEDED to PAINT!

Regions 3 and 1 will be continuing book studies in the summer of 2018. Originally we had thought of continuing in the fall but everyone is too busy with school.

The Bridal Chair, Gloria Goldreich
Sourcebooks Landmarks, March 2015, ISBN 1492603260

Sunflowers, Sheramy Bundrick
HarperCollins Publishers, 2009, ISBN 978-0-06-1765278



Moved or changed your email address?
Go to www.NYSATA.org and update your profile!

Post:

What are your overall thoughts about the Book? About Van Gogh?

Responses:

I absolutely loved the book. I have always talked to my students about how he became famous after he died, but I didn't know all of the detail about the last two years of his life. I liked learning about it through Rachel's perspective and her feelings for him. I feel sorry for Van Gogh, and feel more drawn to his artwork than ever. I cannot wait until "Loving Van Gogh" comes out in November! Thanks for suggesting this book!

I enjoyed this book because it gave a different view of Vincent through the eyes of someone who obviously loved him – even if it was a novel.

Post:

Vincent's mental illness (believed by some scholars today to be bipolar disorder) manifests itself over the course of Gauguin's stay in Arles. Did you see hints of his illness before Gauguin's arrival that Rachel does not notice? What factors made it worsen, do you think?

Responses:

Gauguin's remarks about Vincent's work (ex: your paint is too thick), plus the fact that Gauguin had work sold by Theo added to his mental state. Plus, he really loved her but was afraid of what his family would think. I recently read a theory that a child actually shot Vincent in the stomach and both he and Theo wanted it covered up as not ruin the child – perhaps not a suicide after all. As for the earlier signs of his illness, his loneliness, or the obsessive need to paint, and not taking care of himself may have been indicators she missed.

When I imagined Vincent for this book, I paralleled him with the character Owen from Grey's Anatomy. Owen suffered from PTSD. The frequency of mood swings and obsession to paint by Vincent, mirrored a lot of the scenes I remember Owen going through on Grey's. I also feel that Vincent's isolation from family may have added to his mental illness. I would assume that someone monitoring his behavior may have been able to curb his extreme lows . . . while Rachel was involved, I think a few more sets of eyes may have helped.

Reflecting on Student



Chloe Dudla

Who am I going to be?

Traveling back home for holidays and breaks have always been some of my favorite times of year. But I have now reached the coming-of-age milestone where my looking forward to catching up with family and friends is also the punchline of a pseudo-adult inside joke. My peers and I find both solace and comic relief as we prepare for the inevitable questioning that often involves more pressure than an actual job interview – “So you’re almost done with school right? What are your plans? Where are you going to live? What are you going to do?”.

What am I going to do? Who am I going to be? Having also just finished my high school student teaching placement in December, during peak college application time for seniors, I couldn’t be more empathetic to their similar crossroads. This *deja-vu* of sitting beside my students through college art program presentations, piecing together portfolios, and making big decisions, ignited something in me. What are they going to do? Who are they going to be? As an art educator, how am I going to incorporate student choice in a way that will prepare my students to navigate those choices? During my first few high school lessons, I was shocked at how concerned my students were about whether or not they were exploring right, playing correctly, or brainstorming well enough. Choice, for them, and the notion that a challenge might not have a set solution, seemed paralyzing. Initially, I was frustrated, until I realized that that’s the way that I’m feeling now; facing a multitude of options before my college graduation, none of which are necessarily “correct”. It can be terrifying to be unsure of where to start.

That moment was a turning point for me as an art teacher because it can be equally as thrilling and inspiring as it is frightening to have complete freedom and control. We are not only responsible for teaching the world’s next generation of great contemporary artists. We are responsible for giving each and every one of our students the tools to fearlessly and creatively navigate all of life’s gray areas. I feel a deep sense of responsibility for not only guiding my students through their artistic processes and life decisions, but to get them excited about them as well. I can’t wait to experiment with student choice in my own classroom and find new ways to empower my students to see every new choice as its own unique opportunity. I am now embracing all of the new questions about my future because I’ve decided to practice what I continuously preach to my students; try some new things, make a few mistakes, see where they take you, we can always change it later. Now I just need to figure out where to begin. What am I going to do? Who am I going to be?

Empowering Students

Finishing up the fall semester (my first semester of graduate courses), I had to complete a Classroom Management Plan for one of my final exams. I had to include a philosophical statement, a detailed map and justification of the way I want to arrange my classroom, my expectations, routines and procedures, and several other critical classroom components. While writing this Classroom Management Plan, I was challenged to think of the ways in which I will provide choice to my students when I become a teacher. In fact, this area of the assignment was the one that I struggled with the most, wrote the least, and cited little theory to justify my position. But reflecting on my experiences as a student, choice may be one of the most important ways to empower the learner – to let them know that they are an important, central part of my planning process.



Erin Maloney

Several weeks from now, I will be implementing my second curriculum as an emerging art teacher. Written after completing the Classroom Management course, I was able to see more clearly the areas in which student choice was weak. I incorporated more opportunities to ask my students, “What do you want to learn?” Of course I have constraints and specific projects that I need my students to complete in this eight-week “Saturday Art School,” but I was able to free up some of the ways in which my students can visually problem solve. Inspired by the TAB (Teaching for Artistic Behavior) model, which one of my classmates from the Classroom Management course used in her section on student choice, I incorporated TAB-inspired teaching methods into my lessons. My students all receive the same prompts, but I have given them more choices in the mediums and the ways that they can approach the same project. I want my students to have the ability to choose mediums that truly excite them, so that they can create artwork that successfully conveys their ideas. I can’t wait to see the way that this TAB-oriented unit plan – my second unit plan to date – changes the way that I approach student choice in the classroom. I hope that throughout its implementation I can observe and re-evaluate my theories on student choice.

Chloe Dudla is from Queensbury, NY and is working toward her bachelors and masters in Art Education at Nazareth College. She will graduate in the spring of 2018.

Erin Maloney is from Rochester, NY and is currently working toward her Bachelors and Masters degrees in Art Education at Nazareth College. Erin will graduate in the spring of 2019. Both serve as pre-service representatives on the NYSATA Board of Trustees.



Cory Merchant

Using Social Media to Reinforce Learning



A couple of summers ago I was preparing for another year of teaching AP Photography, and thinking about ways I might stay in touch with students over the summer and provide small, easily absorbed bits of instruction to keep them thinking about photography while they were outside of the classroom.

As a photography teacher, I find myself using Instagram a lot in class. There are a few reasons I think it can be helpful. First, it gets me out of my own comfort zone of teaching about dusty old masters and helps me keep instruction and reference material fresh. Second, it shows that social media can be used for something beyond just interaction with friends and family. There is a whole world of art and artists out there, and every day more of them are putting their work up on Instagram for us to see. Third, it provides reference material to students using a platform that they are already familiar with which can hopefully connect with them more readily. Whenever I find a photographer on Instagram whose work connects with an assignment I've given, I pull up their feed in class and click through some of the images. I think it's been so useful, in fact, that I will soon be implementing a weekly check-in where I list Instagram accounts I think students should consider following.

So, as you can maybe see, it didn't take much of a mental leap for me to realize that I could make my own Instagram account where I could post photographs that I thought held significant educational value and explain why I felt that way. That's how @teachable_photographs was born.

In the beginning there was a concern about copyright infringement, but after no small amount of research I found that my reposting of other photographers' images would constitute "fair use", as I was doing so for educational value. Credit to the original photographer would always be given, as well.

And so, periodically, I will post an image from an established historical or contemporary photographers (examples include W. Eugene Smith, Dorothea Lange, Walker



Evans), and write in the description about how those image-makers used the elements and principles of design in composing their images. I talk about visual emphasis, balance, rhythm, the rule of thirds, the rule of odds, depth-of-field, contrasts, and more. I also then use hashtags to keep the images in categories and easily accessible. Using the example of the Guy Bourdin photograph in image 1, I used general hashtags to increase reach and visibility (like #composition, #design, #photography) and hashtags that reference the specific points I tried to make in the description (like #visualemphasis, #ruleofthirds, #colorcontrast).

When the school year began, after the summer @teachable_photographs was born, I told my students about it. Since then, since it's a public account, some of their friends have followed and other Instagram users have jumped on the bandwagon too. The account has close to 600 followers now. But the numbers aren't really important. It's so easy and quick to do, it would still be worth it even if it only helped one of my students a year.

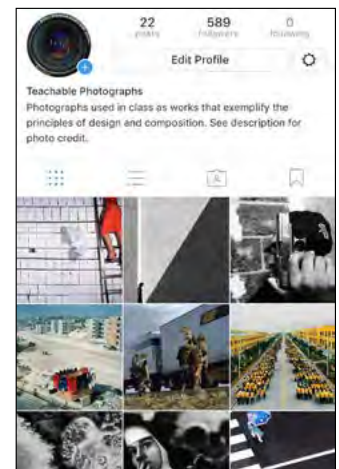

Let's be very clear about something else, too. Instagram isn't only for photographers, there are plenty of illustrators, painters, filmmakers, sculptors, ceramicists, animators, graphic designers, printmakers, sticker makers, graffiti writers, video game designers, and other art teachers too

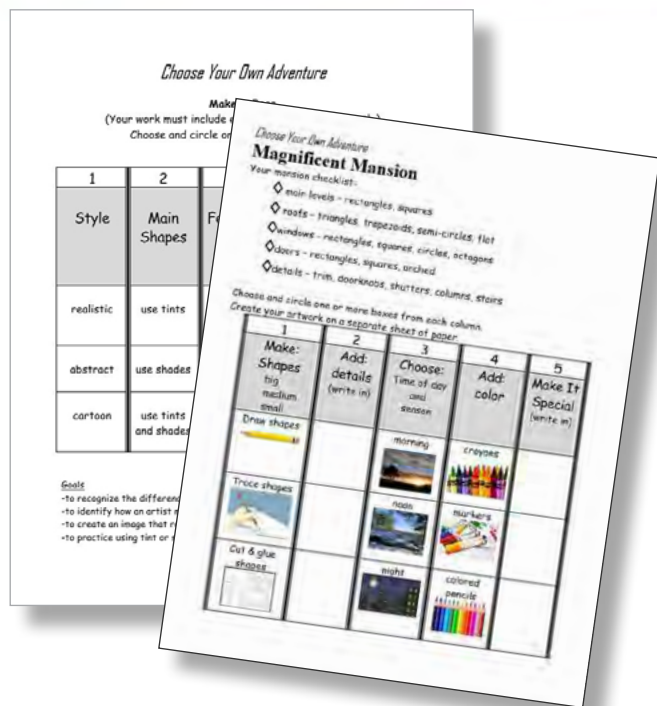

Using Choice Board Organizers in the Art Room

Julie Gratien

“Providing instructional choices creates a learning environment where students of all levels can participate side by side with their peers to create artwork that is meaningful to them.”

Teresa Wildhack and Julie Gratien

In this article, elementary school teacher Julie Gratien maps out the development of a graphic organizer that she has designed to meet her instructional goals and student learning objectives. It not only documents the evolution of an idea, but also provides an insightful narrative that illustrates the power of reflection, the value of incorporating assessment into the refinement of instruction, and the rewards of providing choices for her students in the art making process.

In my 20 years of teaching in the public schools, I have always been reflective on my teaching practices as I tried a variety of methods. My goal has always been to provide enriching art experiences. I was trained in art education as the four New York State Standards for the Arts were adopted in 1996. Art educators focused on four areas: creating; using materials and resources; responding to and analyzing works of art; and understanding the cultural contributions of the arts. As I felt confident in my abilities to teach these four standards, I became more interested in helping students develop their own ideas. I now practice a mixture of skill building lessons and choice-based opportunities. Introducing lessons with broad themes gives me the ability to help students create artwork that expresses their own ideas and interests.

Differentiated Instruction

Recently, I completed classes at our local teaching center taught by Jennifer Rich Walters of Rich Learning that focused on the topic of differentiated instruction. Jen's class

concentrated on Carol Ann Tomlinson's model of Differentiated Instruction. Carol Ann Tomlinson states in her book *How to Differentiate Instruction in Mixed-ability Classrooms*: "In a differentiated classroom, the teacher proactively plans and carries out varied approaches to content, process, and product in anticipation of and response to student differences in readiness, interest, and learning needs" (Tomlinson, 2001, p. 7). In deciding how to best meet the diverse learning needs of my students, the instructional practice of differentiated instruction seems especially appealing.

Choice

Choice in art education is explored in a variety of ways. I knew that choice was a key ingredient to the differentiated approach. Providing instructional choices creates a learning environment where students of all levels can participate side by side with their peers to create artwork that is meaningful to them. Idit Katz and Avi Assor's article *When Choice Motivates and When It Does Not*, 2006, gives insight into three basic needs for students when given choices. Students need

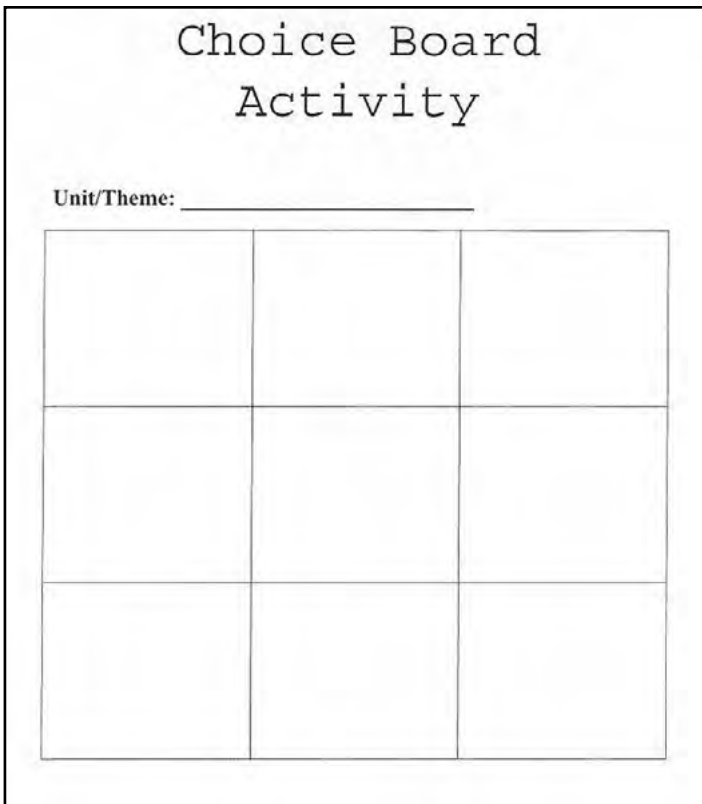

The original choice board activity handout. Image 1

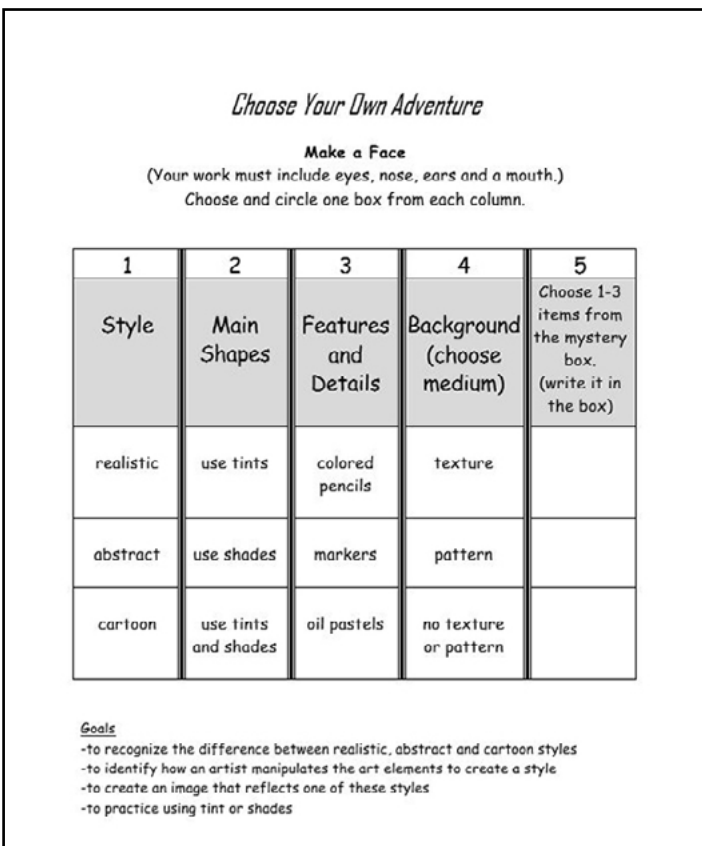

More complex choice board chart. Image 2 © Gratien 2016

autonomy, relatedness, and a need for competence (Assor and Katz, 2006). I teach a total of 485 students in grades K-4. The average of each inclusive class size is 20-25 students. My students come to the art room once every four days for a 45-minute class period. I recognized the importance of choice, but also know that many of my students have difficulty organizing their ideas and supplies during the art making process, especially my grade 2 students.

This led to my development of a choice board graphic organizer. I needed something that served as a visual representation for approaching the art making process. I wanted to design a system that would prompt students to work in a logical order while providing choices and options to suit their readiness, interests and learning profiles. My intent was to not only give choices, but to provide autonomy by offering choices of interest that enabled students to feel confident and capable to complete the task. When Jen Rich Walters introduced me to a variety of graphic organizers, I immediately imagined using a choice board format as a way to organize options for choice-based lessons. Graphic organizers are established teaching tools. In their 1989 article, Horton and Lovitt state "A graphic organizer serves as a nonverbal, visual-spatial referent that cues the learner to the inter-relationships of ideas and their logical connections to higher, equal, or lower order pieces of information" (Horton and Lovitt, 1989, p. 627). Use of graphic organizers is also related to constructivism which is a learning theory initially based on the studies of Piaget and Vygotsky, and expanded upon by contemporary psychologists and biologists (Fosnot, 1996). Constructivism is "a learning theory in which learners construct knowledge from previous experiences by combining prior knowledge and new information to create a new, deeper understanding" (Wachowiak & Clements, 2001, pg. 51). Gardner's theory of multiple intelligences supports that students learn in different ways and the importance of differentiated instruction (Adams, 2008).

The *Choice Board Activity* handout helped me to immediately envision the use of the graphic organizer to help students organize their choices within a broad theme (Image 1). My choice board is designed to organize a student's art making process, acknowledge different skill levels and to provide choices. I designed the *Choose Your Own Adventure* organizer and tested its effectiveness with my third-grade students in the spring of 2016. (Image 2) I chose the theme, *Make a Face*, because I wanted to see what students could do with a broad, but simple theme. I designed the organizer with an awareness of students' previous and newly acquired knowledge. Students already understood the features of the face and how to create textures and patterns. They were well versed with a variety of art materials and recently practiced mixing tints and shades. They analyzed art images of faces and recognized the difference between realistic, cartoon and abstract styles. I also knew that many students enjoyed the tactile quality of art materials and an element of surprise. Therefore, I decided to provide choices from the mystery box (feathers, gems, yarn and wiggly eyes).

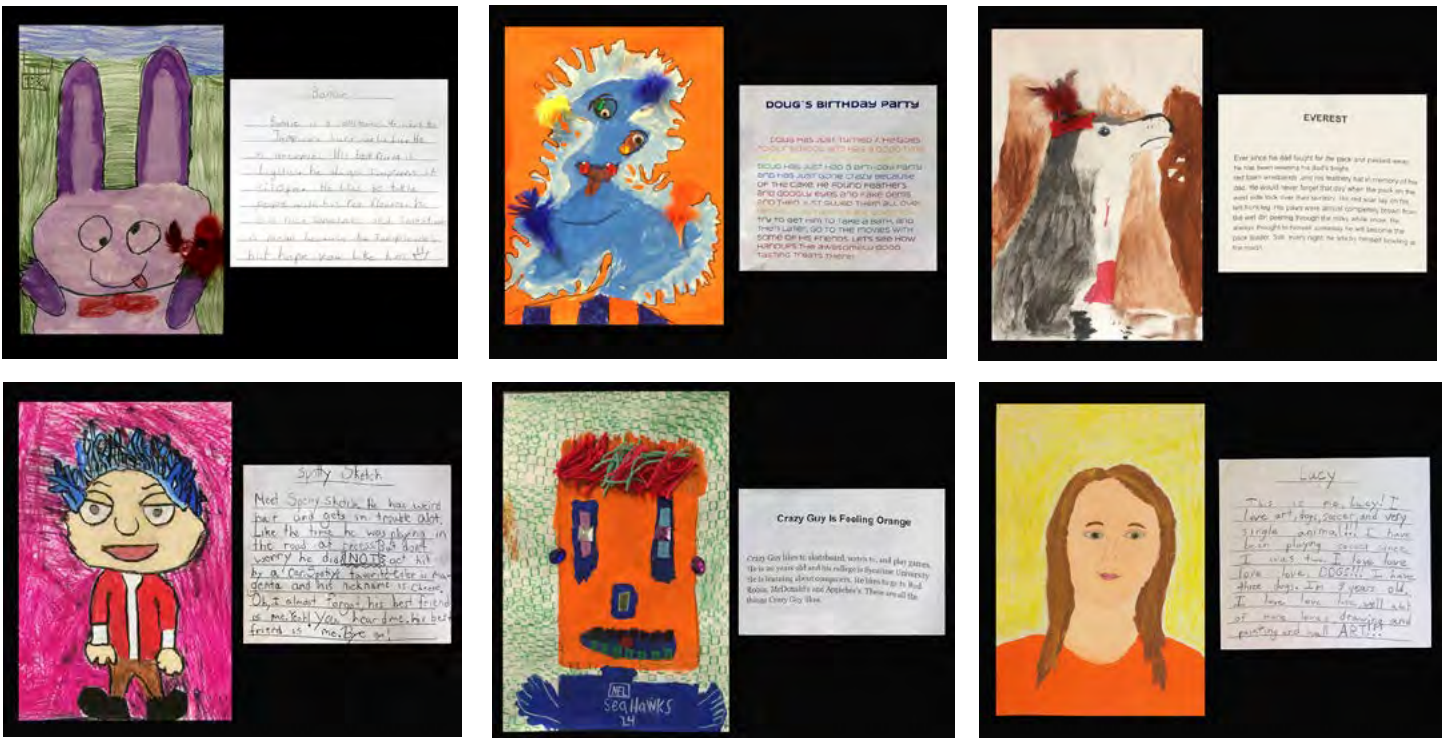

Student work that used the Make-a-Face Choice Board Organizer. Image 3

I was pleased with students' initial reactions. As soon as I introduced the graphic organizer, they were motivated to work. I provided references as needed based on their ideas. I was happy to see that because the students were generating their own images, they were self-directed and self-paced. They also easily decided when the work was complete. I was delighted with the variety of the results: human faces, animal faces, and a combination. Students were able to work more independently and at their own level. Students seemed especially engaged and encouraging of each other. Each image was unique. Students wrote about their work upon completion to more fully express the ideas in their images (Image 3).

The 2016-17 Challenge

In the fall of 2016, I was challenged with a unique situation as an art teacher. My second-grade students had a broader range of mixed abilities than usual. Several students were more than ready for the content of the 2nd grade art curriculum, yet many students were much less ready. I have been trying various methods to differentiate instruction for all my students in grades K-4, but I knew that I would need to develop something specifically for this group of 100 second grade students. My goal was to help students improve their ability to develop images independently, increase participation and to improve their understanding of art making concepts; I also recognized that students would need multiple choices to stay engaged and focused. I hoped to reduce anxiety and prevent boredom for my students and give them more ownership over their images. I wanted to provide enriching art experiences and help each student to feel successful.

Meanwhile, Dr. Craig Tice, our district's superintendent, offered teachers the opportunity to conduct an action research project. Action research is "any investigation conducted by the person or the people empowered to take action concerning

their own actions, for the purpose of improving their future action" (Sagor, 2011, p.5). I recognized action research as a valuable process in my pursuit to strengthen my own teaching practices. This study was a chance to improve upon and test the potential of my choice board graphic organizer. I enlisted the help of Teresa Wildhack, an occupational therapist who works with my students in need. She became a supporting partner focusing on the research of literature about our topic, in the analysis process and in data collection. Dr. John Tillotson from Syracuse University and his graduate students provided guidance for our research.

Incredible Insects

I introduced my second-grade students to the choice board graphic organizer during a lesson in September. The lesson was titled *Incredible Insects*. I included a list of facts about insects on the graphic organizer and I displayed a poster with images of a variety of insects in the art room. My

Incredible Insects

Facts about insects:

- 3 body parts: head, thorax and abdomen
- 6 legs; attached to thorax
- 2 antennae; attached to head
- Most have compound eyes; on head
- Most have wings; attached to thorax



Make a real or imaginary insect
Use the choice board below
(Choose one or more from each column)

| Style | Shapes | Color | Other | Extras |
|-------------|---------------------|--------------------------|-------------------------|------------------|
| real | Draw shapes | Use crayon for color | Add Texture | Add Glitter glue |
| combination | Trace shapes | Use oil pastel for color | Add patterns | Add feathers |
| imaginary | Cut and glue shapes | Use markers for color | Add texture and pattern | Add foam shapes |

(© Gratten, 2016)

goal was to peak students' interest and also verify the basic insect facts. I provided them with options regarding the style, shapes, supplies, texture, pattern, and extras.

From that experience, I discovered that many students were unable to read the vocabulary I included on the graphic organizer. As



Student artwork done using the Incredible Insect board organizer.

a reflection on the *Incredible Insect* lesson, I also identified the areas where students were not understanding art making concepts on grade level: drawing basic shapes; making the large shapes, then medium, then small shapes and details; and making their image stand out through the use of contrast and good craftsmanship. These areas became the year's focus for my second-grade art instruction.

Magnificent Mansions

After working on skill building lessons for several classes, students were ready for another choice-based lesson. I tried to improve on the design of this choice board by supplying a checklist at the top, numbered columns, adding images and two "write-in" columns. Leading up to the project, students learned more about drawing geometric shapes, identifying and using light, dark, warm and cool colors, all concepts that would help with the Magnificent Mansion lesson. They were introduced to the lesson by watching a video that I pre-recorded of my visual demonstration and verbal explanation. The video provided a way to make sure that every student received equal instruction. Any students who were absent watched the instructional video during their next art session. The video clip provided the objectives of the lesson, a logical work order, images of supply options, resources and handouts, and an explanation of the various choices. In addition, I read and explained a projected image of the organizer and gave students their own

paper copy. Students spent three class periods on their artwork.

As students worked, I noticed they were not using the organizer. I had to say "Stop. Look at the checklist at the top and check off what you completed. Look at your choice board and circle the choices you already made. Write in any extra choices." I had to re-read the information on the choice board to those students who were unable to read it independently. I did see improvement in students' artwork and the images were more varied (Figure 6). Students were beginning to take ownership and referred to the artwork as "my mansion," therefore expressing autonomy, but I was wondering why students were not fully using the choice board.

Upon completion of their mansion, I gave students a questionnaire about their experience, which gave me additional insight into what stages of the projects the students liked and disliked. I learned that many of the students did not like making the initial shapes and compositional decisions. They were more interested in drawing the details. I realized that as a practicing artist, I also am intimidated by the initial compositional decisions, but once made, I enjoy developing the details in my artwork.

Students also commented on the use of the choice board. Only one student vocalized that she enjoyed the write-in columns. Many students commented that did not like

Choose Your Own Adventure
Magnificent Mansion
 Your mansion checklist:

- ◇ main levels - rectangles, squares
- ◇ roofs - triangles, trapezoids, semi-circles, flat
- ◇ windows - rectangles, squares, circles, octagons
- ◇ doors - rectangles, squares, arched
- ◇ details - trim, doorknobs, shutters, columns, stairs

Choose and circle one or more boxes from each column.
 Create your artwork on a separate sheet of paper.

| 1 | 2 | 3 | 4 | 5 |
|--|--------------------------------------|--|------------------------|--|
| Make: Shapes big medium small | Add: details (write in) | Choose: Time of day and season | Add: color | Make It Special (write in) |
| Draw shapes | | morning | crayons | |
| Trace shapes | | noon | markers | |
| Cut & glue shapes | | night | colored pencils | |

© Gratien 2017



Student artwork done using the Magnificent Mansion board organizer.



columns as in the mansion organizer, all with black and white images and simple words. I also added a space for the artwork title for students that think of a title as they tell their story with images. This time I noticed an increase in the immediate use of the graphic organizer. Many students went back to their seats, made their choices and even filled in their title. The simplified design was more student friendly and students were not reluctant to use it. They more fully utilized the choice board. Students of all abilities were engaged. Students were self-paced and worked more independently and were prouder of their work. They had less anxiety. Given more choice, students took ownership of their work and I was especially pleased that the outcomes were varied (images on next page). I was providing an enriching art experience where the children were the actual creators of their own work.

stopping to circle things. They wanted to keep going and already knew what they were doing. They said that they didn't need the choice board. They felt that the choice board organizer slowed them down. I realized that the checklist was too wordy and that most students did not like the write-in boxes, especially the non-readers. Because my goal was to help students become more independent, engaged and to more fully understand art making concepts through the use of the choice board, I knew that I needed to redesign the format again for choice-based lessons to make it more "student-friendly".

Animal in a Landscape

Two months later, it was time to try another choice-based lesson. In the three sessions leading up to the lesson, students practiced three ways to make an animal image.

They used "how to draw cat and dog" handouts, learned

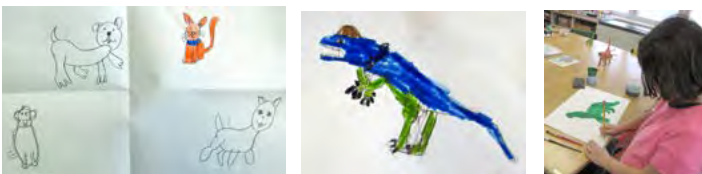

how to draw toy animals by drawing shapes and contour line, and learned to draw with paint and a brush. This prepared students for the choices they would have in the *Animals in a Landscape* lesson. Students had also just finished a social studies unit about urban, suburban, and rural communities. I decided that this would be a perfect opportunity to build on their current knowledge and to integrate it with landscape drawing skills as it was fresh in their mind. I also gave students the opportunity to emphasize the animal or the landscape based on their interest. Again, students were introduced to the lesson by watching my videotaped demonstration and explanation. As in the mansion lesson, students spent three class periods on their work.

I set out to improve the choice board for this lesson. I eliminated the checklist at the top (too many words) and the "write in" columns (too many choices). The organizer had five

Name _____ Class _____

Choose Your Own Adventure
Animal in a Landscape
 Make your choices.
 Create your artwork on a separate sheet of paper.

| | | | | |
|-------------------|--------------|---------------|-------------------|---------------------|
| 1 | 2 | 3 | 4 | 5 |
| Animal | Landscape | ★ #1 | Animal | Color |
| Cat | Urban | Animal | Draw | Crayons |
| Dog | Suburban | Landscape | Color and cut | Markers |
| Other animal ? | Rural | | Paint and cut | Colored pencils |

Title of your artwork: _____

© Gratiem 2017

When questioned, more students liked the choice board and said it was helpful because it made them "think before they got started." It helped to "show them what to do next." Some students commented that it took too much time and slowed them down. Teresa Wildhack and I began thinking about whether "slowing down" was a good or bad thing. We realized that students need time to get used to using the organizer and concluded that having to "slow down" was a positive influence. Students began thinking about their choices instead of just reacting to instruction.

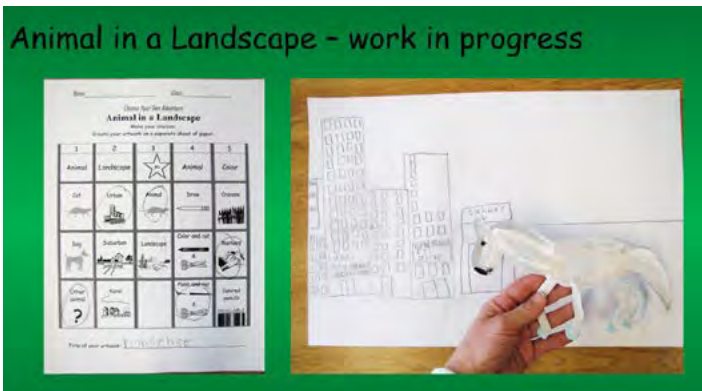

Student artwork done using the Incredible Animal in a Landscape organizer.

So, “Why Use Choice Board Graphic Organizers?”

Through my study I learned that the choice board graphic organizer provided students with the support they needed to work more independently at their own pace. Students of all abilities were more fully engaged, took ownership and were prouder of their work. I recognize that the choice board gave these students a way to keep organized from week to week and by redesigning the choice board, students had more success. Will choice board graphic organizers work with every student and every lesson? Probably not, but we gathered enough evidence that I believe it is worthy of further exploration. My plan of action is to continue to use the organizer for choice-based lessons with students in my quest to provide enriching art experiences for all of my students.

References

Adams, K. W. (2008). “The relationship between art education and student achievement in elementary schools” (Order No. 3337321). Available from ProQuest Dissertations & Theses Global. (304386508). Pg. 43-59

Assor, A., and Katz, I. (2006). “When choice motivates and when it does not.” *Educational Psychology Review*, Vol. 19, No. 4 (2007), Pg. 429-442.

Fosnot, C. T., and Perry, R.S. (1996). “Constructivism: A psychological theory of learning.” *Constructivism: Theory, Perspectives, and Practice 2* (1996), Pg. 8-33.

Horton, S. V., & Lovitt, T. C. (1989). “Construction and implications of graphic organizers for academically handicapped and regular secondary students.” *Academic Therapy*, 24, Pg. 625-641.

Sagor, R. (2011). *The Action Research Guidebook: A Four-Stage Process for Educators and School Teams*. Thousand Oaks, California: Corwin.

Tomlinson, C.A. (2001). *How to Differentiate Instruction in Mixed-ability Classrooms*. Alexandria, VA: Association for Supervision and Curriculum Development.

Wachowiak, F., and Clements, R.D. (2001). *Emphasis Art: A qualitative art program for elementary and middle schools*. London, England: Longman Publishing Group.



Julie Gratien has been an art educator for 22 years and is currently at Fayetteville Elementary School. She achieved National Board Certification in Early and Middle Childhood Art in 2009 and was the 2008 recipient of the Ray Henry Award and the Art Educator of the Year for Region 3. Julie values her involvement in NYSATA as it is a way to

learn from the pros and has shared her experiences by presenting and coordinating workshops for the region and at the State Conference. You can contact Julie by email: julie.gratien@gmail.com



Cultivating Curiosity: Choice in the Art Room

Amy Mottola

Here Amy Mottola delineates her motivation and process as she adopts aspects of choice-based curriculum design featured in a “Teaching For Artistic Behaviors”, or TAB, approach. In the course of the article she clearly shares her compelling observations about the value of choice – for herself and her students.

You might be wondering what the hubbub about this choice-based art curriculum is all about. This movement has been growing over the past decade, with increasing presence in NYSATA and NAEA conferences. There is no right approach or way to fold this transformative approach into your teaching practice. Jumping head first into Teaching for Artistic Behavior in the middle of a graduate thesis is not something I highly recommend, but I do hope my experiences will inspire you to at least dip your toes in.

So why choice-based and why Teaching for Artistic Behavior? Teaching for Artistic Behavior (TAB) is a nationally recognized art education approach developed through 35 years of research at Massachusetts College of Art, and is a concept that enables students to experience working as an artist through authentic learning opportunities and responsive teaching. For anyone who loves to get lost in the process of art-making, we owe our students the same experience of finding that perfect color or considering new possibilities for an idea. Cookie cutter lessons don't truly teach artistic behaviors like observing, envisioning or exploring because that has already been taken care of by the teacher. The Teaching for Artistic Behavior approach specifically focuses on the philosophy that all children are artists. I have found my 3 ½ years of teaching through TAB has been most transformative, not only for me but for my students in both private and public settings.

Choice-based art curriculums shift the learning environment between teachers and students. When we, as teachers, give up our definitive expertise and acknowledge our students' wealth of experiences as sources of knowledge, we find they are capable of generating their own creative problems and solving them in the ways they understand best. I see my role as a facilitator or a guide who exposes them to many new possible ways to make, see, and understand art.

The classroom itself becomes a third educator, through the use of clear procedures, vast visual references and the effective organization of materials.

The space is set up into centers, or collections of tools and resource material, based on media. The classroom acts like a communal studio space that allows for collaboration through dialogue and interaction. Students are able to move independently to find their materials and create according to their interests and skill level. Social and cognitive constructivism thrives in this environment. Choice in materials/mediums and projects allows for students to have agency in creating what matters to them most, all while building on their understanding for skills and concepts. Instruction is presented in small chunks and varies between whole group, small group and one-on-one. The teacher and students mediate the learning process through multiple perspectives. Creative problems don't have one answer, but based on the diverse experiences of the classroom participants, there can be potentially numerous responses available. Every week, my students bring in stories, ideas, and concepts connected to their artwork that I never considered. If there

Teaching for Artistic Behavior (TAB) is a nationally recognized art education approach developed through 35 years of research at Massachusetts College of Art, and is a concept that enables students to experience working as an artist through authentic learning opportunities and responsive teaching.



City Building



Art Mexpo



Miex and Logan at work on their scroll



Group at work on scrolls

are any questions about technical issues or idea development, turning the question back to the class at large, presents many more options than I could produce. It also allows the inquiring student to take the advice that best fits their intention.

My experience in both private and public settings have confirmed the value in teaching choice. While each have different schedules and expectations, I have found TAB is easily adaptable to many situations. While teaching preschool to 12th grade in a private school, I taught often in project-based periods, collaborating with the classroom teacher, as well as the science teacher and librarian. This integrated time allows students the opportunity to explore a theme through multiple disciplines over at least a quarter, and in some cases the whole year. Often the projects stemmed from student inquiry. Imagine a year's worth of research based solely on the question from a 6th grader, "What happens to your trash when you throw it out?" This inquiry led us all, students and teachers alike, down wormholes of analyzing our trash, finding statistics on food waste, creating guerrilla theater skits on composting, volunteering for Meals on Wheels and visiting an animal sanctuary. This integration informed my teaching because it offered using disciplinary knowledge within the art studio to redefine creative solutions. What if we made art like a scientist? How would we predict our creative outcomes? How might a mathematician make art? What methods would we use to make creative decisions?

Art was the place where boundaries between these disciplines could blur and be just another tool to investigate an idea. I found through my research that by modeling these kind of inquiry behaviors, students were more apt to experiment in their artwork and view their peers' work and feedback as equally helpful in furthering their own ideas and skills. For example, I had two kindergartners who couldn't wean themselves off of drawing with only stencils and markers for the first half of the year. A suggestion from a peer about shifting their drawings into a story turned into several months of building a scroll out of the series of ever more complex drawings. Soon the act of drawing began to include the help of several other classmates who would all work on the floor together. My two students soon outgrew their reliance on stencils because peers believed in their ideas and they felt supported enough to take that risk.

Choice-based art curriculums encourage the importance of play and experimentation as sources of knowledge to draw from in the development of ideas. When students are at the painting center, it doesn't take long for the "splatter urge" to kick in. Making the action of art visible continues to be a necessary development for students. Allowing the time to experiment with the physical qualities of the paint and movement between the brush and the body is a valid experiment. The harder part for an artist is how to turn these experiments into something with more "meat". I take inspiration from TAB teacher Clyde Gaw's blog and podcasts, where he describes breaking media and skills up into Play periods and Care periods. Allowing students the time to explore a material or application during a "Play" period gives them the awareness of what's possible. Hypotheses are made and tested and that information is collected to advise new projects. The "Care" periods then offer students the ability to engage with the ideas and process from a deeper awareness with the intention to create meaning. During the Care period I intervene with artistic context, offering art history examples and wonder about media crossover as potential directions. Ultimately, the students choose how they reflect back what they learned through that experimental process.

In public school, the sheer number of students moving through one's art room can seem daunting. I have found that offering choice, even if that means limiting the choices available for sanity sake, still has a profound effect on student engagement, especially when your demographic is mostly low income where the ability to choose in life is infrequent. The art studio space becomes one of the few places where children artists decide the direction and focus of their learning. Here I've observed the creative struggles of collaborative work, technical issues, and idea



Action Painting in Action

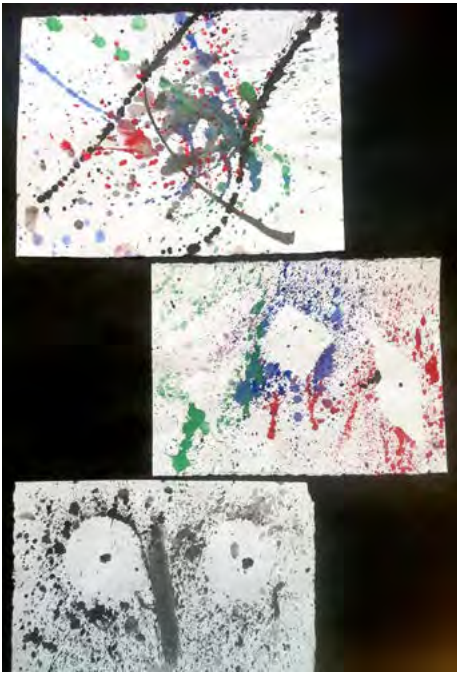

Splatter Paintings



Hunter and his paper sculpture

generation. My young artists look and sound like professional artists. I've noticed groups of children spend weeks building and collaborating on the design of a hotel through wooden blocks and blueprint drawings. Currently it has four floors with a pool and a pet store. I've observed another student struggle several classes to master creating a free standing paper sculpture on his own. Yet each class he is nearly beaming as he discusses at share time what he learned and what he still needs to work on, with his classmates eager to give their own feedback and support. The learning that takes place in these moments reflects the needs and interests of the students as they change and build upon skills and concepts.

This emergent curriculum, one that grows from the interests of the students, transforms the art room truly into a vibrant and rich studio space. I am learning alongside my young artists about the finer points of mixing skin tones, creating new Pokemon characters and constructing boathouses. Despite having 540 students, I still feel that teaching TAB allows me the ability to truly know my students individually. I can remember their projects, whether they are a 2D or a 3D thinker, but also where they get stuck. TAB allows me the ability to help where needed and stay clear when things are flowing. Clearly, my work is cut out for me. I am always developing new ways to teach a skill or concept. I strive for my young artists to dig ever deeper on their ideas, stick with it even when it gets hard. Not because I'm the teacher, but because I know firsthand as an artist what it feels like to be stuck and to succeed. That trust and rapport are essential to our collective studio work.

Convinced that this is the land of milk and honey? It's not a matter of drinking the Kool-Aid. Bringing choice into your art room can come in small steps, especially because the organization and relinquishing of teacher control can be daunting at first. Choose a lesson that offers students choices in materials or genres. Offer a play/experimental time when introducing a new material and discuss what they discovered and possible new applications. Working choice into your curriculum also takes support. Look for teacher/administrative allies in your department or school who have similar leanings and find ways to collaborate. There are plenty of resources online. (Pinterest, anyone?) Lastly and most importantly, don't overlook the curiosity in you that got you started on a creative life in the first place. Don't forget you are a maker too and that it is an important part of who you are. If you want to instill creativity in your students for life, don't let that flame go out in you. Make an art date with yourself every week. Meet up with art friends and share your artwork. Always be curious! Young artists will notice and aspire to this working artist in their midst!

Resources

Teaching For Artistic Behaviors

<http://teachingforartisticbehavior.org/>

Transition To Choice Based Art Education – a blog by Clyde Gaw

<http://clydegaw.blogspot.com/>

Jaquith, D & Hathaway, N. (2011). *The Learner-Directed Classroom: Developing Creative Thinking Skills Through Art*. New York, NY, Teachers College Press.



Amy Mottola has been sharing her love for art making and teaching in the Hudson Valley for over 10 years. She is a three time graduate from SUNY New Paltz (BFA, BS, MsED) where she gained a vigorous love for research. Since 2017, she teaches K-5 at Ellenville CSD in southern Ulster County. She has presented her experiences with choice-based art curriculum at state and local NYSATA workshops. Her personal artwork spans painting, drawing and ceramics and explores themes of spirituality, black holes and geometry.

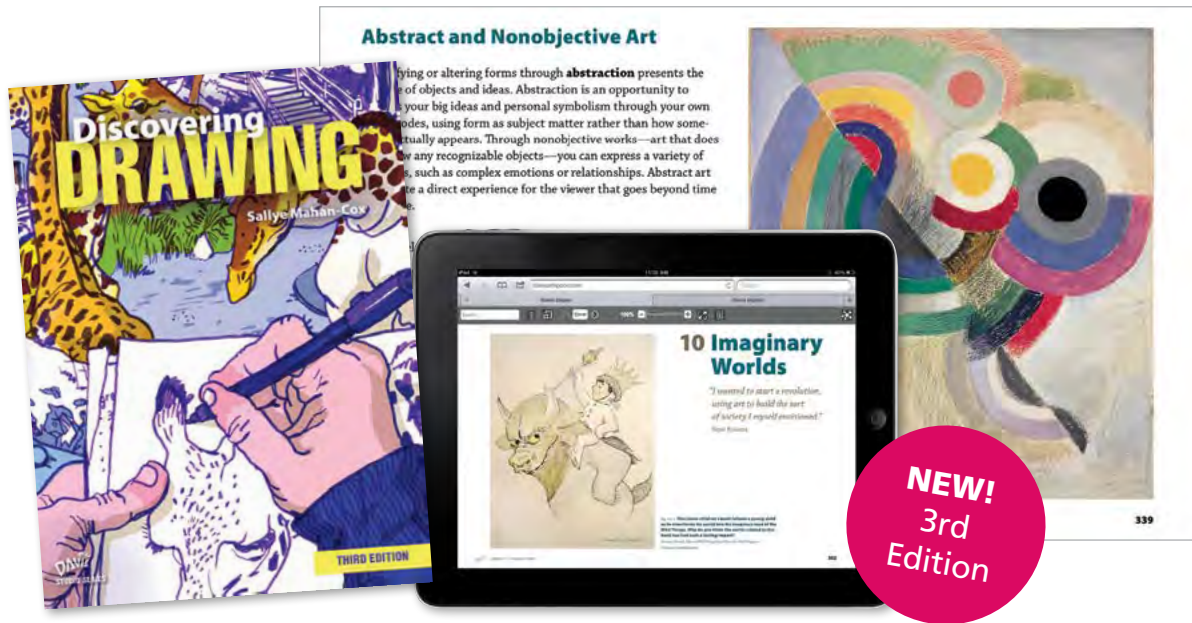

Discovering Drawing

THIRD EDITION

By Sallye Mahan-Cox

Emphasizing both technique and creativity, the 3rd edition of *Discovering Drawing* highlights the importance of discipline and self expression in this essential skill. Students explore **both realistic and expressive drawing techniques** through stimulating **hands-on studio opportunities**. Master artworks, portfolio tips, interviews and profiles of professionals, and connections to design make this the most comprehensive guide to drawing available for the unique demands of contemporary classrooms.

Highlights include:

- Exemplary studios, from Conducting an Investigation to creating a Visual Conversation
- Stunning fine art examples from historical and contemporary artists
- An in-depth Student Handbook with essential information on techniques and processes including detailed instruction on how to photograph your work.
- A wealth of art history and nontraditional approaches expand your students' knowledge of contemporary art and our visual world.
- Extensive coverage of art fundamentals and their use in drawing
- Comprehensive lessons including Creating Narrative Art and Art from the Imagination, Drawing from Observation and Using Linear Perspective

Contact your local representative, Russ Pizzuto, at 716-430-2111 or email RPizzuto@DavisArt.com.



Go to [DavisArt.com/Sample](https://www.davisart.com/sample) to sample the eBook.

Davis Publications | website [DavisArt.com](https://www.davisart.com) | phone 800.533.2847 | email ContactUs@DavisArt.com



What College Never Told You About Being An Art Educator

Courtney Yacuzzo

Starting a new job in a new place has got to be one of life's most daunting experiences. In this article Courtney Yacuzzo, (a veteran art teacher who still remembers her humble beginnings) gives advice on negotiating the unique challenges facing emergent teachers who needs to organize strategically, find resources, and methodically wrestle circumstance and environment into a productive, effective, efficient workplace for learning.

You've nailed the interview, the school district has asked you to become part of the team, and as soon as you sign some paper work you are officially the art teacher! But now what? The overwhelming sensation of excitement mixed with trepidation and fear has crept in and you find yourself rapidly breathing. You'll be the "newbie", the "green teacher". There will be new ropes to learn, new faces, names, etc..

I've found myself in this position, three times in my career, at vastly different districts. While I valued my time as an undergrad visual art and art education major, it goes without saying that there are many aspects of the job that were not covered in higher ed. curriculum. Some things I've had to learn the hard way, or several different ways (as no two school districts are the same!). The following are the valuable 'gems' I have picked up during my 7 years as an art educator.

Who to befriend first?

There are a few groups of hardworking people you want in your corner: building secretaries, payroll, maintenance staff, and the IT department. Everyone working in these areas is not only essential for a school to function properly, but they have a job that is much needed but not desired. They do, however, know the ins and outs of the school better than anyone else. Need to know where a specific form is and who to turn it in to? Your building secretary can tell you. Confused about part of your paycheck? Just look to payroll. Need assistance cleaning out the paint and clay filled sink trap? Maintenance can help! Desperately need Pinterest unblocked to help the creative juices flowing – IT has your solution! Treat

these people well and you'll be surprised how helpful they can be as you get your feet wet in your new position.

Aside from these individuals, your mentor is another great asset. Even if you've already worked at a different district before, your mentor can guide you through some aspects of the school that may be new to you. Be humble! Despite believing you've been 'seasoned' by working previously, there is still much to learn about the interworkings of your new place of employment. Being meek and respectful will undoubtedly get you far with this veteran teacher. Listen to your assigned mentor: since this can be a paid position, take full advantage of them, even if you feel like you might not 'jive' at first. Ask questions, discuss concerns you have, share ideas with them – they can be a tremendous resource and wealth of information. Not to mention, you are building a professional relationship that can have its advantages for years to come.

Inheriting the hoarding: What to keep, what to get rid of, and where to start?

Let's face it; art teachers, while great at reusing and repurposing items, can be, at times, gigantic pack rats. In the three districts where I have been employed, I have followed someone who had spent their whole 30-plus-year career at the district, and left behind both a lot of useful items and even more 'junk'. While its great to recycle items, it's also even more beneficial to have a fully functioning art room that is free of clutter.

If you walk into a mess, it can be extremely overwhelming – but remember this: Rome was not built in a day, and neither will your art room. While you can dream that organization will happen quickly, it could be a much longer process than you anticipate.

Here are my tips for dealing with a mess:

- *Figure out your ‘clean’ priorities and start there:* Do you want to start the year with student supplies organized? Will you need to use the kiln for ceramics and need to clean the space around it to make it less of a fire hazard? For each teacher this answer will be different, but pinpoint what you need cleaned ASAP, and focus on that first.



Before: Is there a kiln under all that junk? After: The kiln room is no longer a fire hazard.

- *Clean and organize in phases:* this is especially vital if you have multiple rooms (possibly storage rooms, kiln rooms, dark rooms, etc.). It is physically impossible for one person to go through piles and piles of artwork, examples, and supplies in just a week. Set a large goal to go through and organize certain areas of the room or specific supply rooms. This way you’re not doing it all at once and getting in over your head.

- *Create a “shared supplies” area with any ‘left over’ materials:* if you’re fortunate enough to have a wealth of supplies left over after you sort through all that you have, create a shared supplies area for teachers and students to take and use at their leisure. This can be especially great for items that may not be the best quality (like partly sun-bleached construction paper or that box of short and stubby colored pencils). Typically I make this area in the teachers’ lounge clearly labeled. When a teacher needs an item they can sign them out (for returnable nonconsumable items like scissors) and use them as they please. This also helps cut down on the seemingly constant interruptions during class instruction: “Hey – can I borrow . . . ?” Not to mention creating a shared supplies area has always made me fast friends with teachers who don’t have a budget for such items, and use the resource frequently



A shared supplies area solves several problems

- *Save old budgets, requisitions, and catalogs.* Often

times prior to a new hire, the budget is cut considerably or a least ‘trimmed’. Save any requisitions, budget breakdowns, and even old art supply catalogs you find. This can be used later to defend and restore the budget, as you will be able to prove that the cost of art supplies has only increased.

Have realistic goals:

As creative-minded individuals, we tend to be dreamers, always thinking of new and exciting things to incorporate into our classroom. While this is a fantastic trait to have, it can also be a major flaw. Even though your administrator may be excited for the changes you want to make to the department, there’s no way they can financially support a complete creative suite equipped with a class full of computers, cameras, and lighting for a course you want to run next semester. Be realistic: while it doesn’t hurt to ask for funding, especially if you’re enhancing the program in any way, understand that good things take time, and you may need to get creative with how to achieve high bar aspirations.

Making the most of a meager budget:

As college students we often times had to choose between eating that week, or paying for supplies for our studio classes, so when you are first supplied with your budget you may think “I get to spend ALL THIS on materials?!” Any amount seems high as compared to the little means we had as undergrad art students. As time goes by you quickly discover how fast students can go through a yearly budget, making what you initially thought of as a gigantic amount of funding, seem quite tight. There are so many ways to extend and supplement your budget, here are just a few:

- *Find it free:* do you have a local sign shop? Chances are they will donate their vinyl and corrugated plastic strips for free (which can lead to a lot of sticker and sculpture projects!). Paint shops are quick to get rid of the previous seasons paint swatches (can you image all of the collage projects?!). Even larger chain stores might be willing to make a modest donation of materials if you mention their generosity in a school newsletter. Don’t be afraid to ask!



Free vinyl scraps acquired from a sign shop

- *Find it in your school:* Do you need furniture? Ask the maintenance staff to take a peek in storage for things other teachers might have gotten rid of. A cabinet for sheet music can be easily transformed for student sketchbook storage, an old filing cabinet can organize all those loose magazines you use for collaging. This can save you hundreds, especially if you are creative with how you use it!

- *Be aware of other forms of funding.* Did you know that sketchbooks are considered a textbook in New York State and can be covered under state textbook aid? There are so

many other ways you can get creative with how you find funds for your classroom. DonorsChoose is an excellent website to get materials you may not have anticipated or planned for. While it won't cover everything, it can be helpful for collaborative and community-based projects.

- *Ask for equipment and other big ticket items in early spring:* School budgets typically end around February or March, meaning if there is any leftover funds, administrators might be quick to spend it prior to when the new one rolls out. I've found this is a great time to ask for those items that may be a bit too 'rich' for your budget: display panels, kiln maintenance or repair, and other expenses.



A 'make and take' activity done at the district art show with vinyl scraps

- *Start grad school sooner rather than later:* take it from someone who waited way too long to do this and ended

up getting a certification extension. You'll save yourself a lot of time and stress doing it ASAP, plus if you do it soon after your undergraduate degree, you'll still be accustomed to writing academically and won't be so rusty.

- *Don't be afraid to make your own traditions,* but don't phase out the old ones too quickly: This is one I'll admit I had to learn the hard way. Always eager to try something new, I may have phased out rituals that had been in place for years without thinking of how that could disrupt the school culture. Be patient, you can make your mark without causing too many waves during your first year or two.

Lastly, while this is easy to forget on the stressful days, remember that you are the Art teacher, and have the best job in the school!



Courtney Yacuzzo is currently the high school art educator at Bath Haverling High School in Bath NY. She is a graduate of Alfred University. Highly influenced by her interdisciplinary undergraduate work, she employs problem-based learning in the wide variety of courses she teaches.



MSEd IN VISUAL ART EDUCATION

Connecting contemporary artistic practice with critical art pedagogy

Low-residency 15-month program:
2 summers in residence on campus
2 online semesters

Still accepting applications—Apply Now!
www.newpaltz.edu/arted

Contact us:
arteducation@newpaltz.edu



“The School of Fine & Performing Arts is at the center of the College's mission to be a cultural hub for the region. Come join us and be part of the power of art!”

arteducation@newpaltz.edu



Kathleen Hallam-Bushek and Jill Cannon with the newspaper STEAM challenge, Conference 2017

STEAM

A report from STEAM Co-chairs Kathleen Hallam-Bushek and Jill Cannon

The STEAM Committee was pleased to present the Newspaper Challenge at our recent 2017 NYSATA Conference. Engaging students in STEAM challenges encourages a holistic approach in the STEM learning processes. It ‘models’ on another plane that gives the ‘right side of the brain’ more credence while still presenting growth opportunity. The arts are the key components needed to generate and inspire innovation in students’ educational experiences.

We will present more STEAM challenges in the future and encourage members to share what challenges they have engaged their students in.

The STEAM committee has already begun to focus on the 2018 NYSATA Conference STEAM Challenge and we are at work developing a STEAM Thread for this conference. Members interested in presenting STEAM workshops, please let us know! Email kbushek@ffcsd.org.

Many school districts focus on STEM because they are not aware of the benefit of STEAM. We are working on a presentation that members can download to advocate for STEAM in their school districts. This tool can strengthen an existing art program not only by quantifying the need for it but by showing how art is integrated with other disciplines.

Updates and Reports from Committees, Project Chairs, and Leaders

OLYMPICS OF THE VISUAL ARTS

What’s shaking at OVA, from Co-Chair Anne Manzella

NYSATA’s 36th Olympics of the Visual Arts event (OVA) will take place this year on Wednesday, April 25th at the Saratoga Springs City Center. Last year 38 school districts from our regions across the state registered 877 students who participated, presenting 208 total design solutions, elementary through high school level. Over 50 professionals from creative careers also participated, adjudicating the design solutions. We welcome all districts to register their teams for this year’s event on the NYSATA webpage by March 15th. We also are recruiting new volunteers to serve as judges and on-site coordinators. Please email Anne Manzella at amanzella@ncolonie.com for information about volunteering to help make OVA a success again this year.



2017 OVA Illustration Entry



Plein air painting demonstration at Camp Sagamore Summer 2017

Sagamore Summer Camp

Update from Co-chairs Michelle Schroeder and Beth Atkinson

The New York State Art Teachers Association Summer Institute at Great Camp Sagamore is already filling up for our week of art making August 5-11. We will be offering over 50 hours of hands on workshops in an incredibly beautiful Adirondack environment. Spots fill up quickly, so if anyone is planning on attending they should register soon.

The cost for members is \$1000 before April 1st, after April 1st the member price goes up to \$1050. The non-member early bird price before April 1st is \$1050 and after that date it goes up to \$1125. The price includes room, meals, some materials, certificate of participation, and CTLE credit. There are 2 scholarships available for teachers who have not attended the program in the past through the NYSATA Barry Hopkins Art Educator Scholarship. One is a full tuition scholarship for the week and the other is a half tuition scholarship. The applications were available on the NYSATA website and must have been postmarked by January 30, 2018. Any questions just contact Beth Atkinson: bethatkinson12@hotmail.com or Michelle Schroeder: sodrawme623@roadrunner.com.



NEW YORK STATE COUNCIL OF EDUCATION ASSOCIATIONS (NYSCEA)

A brief report from Dr. Patricia Wheelhouse, our NYSATA NYSCEA Representative, on items discussed at a recent meeting.

In a press release dated 1/16/18, the *Every Student Succeeds Act (ESSA)* now includes the arts as important and central subjects for students to study. Previously only math and science were mentioned.

214 positions have recently been approved by NYSED. For more information, see <http://www.nysed/hr/employment/employment> opportunities. Leslie Yolen will retire in April. There will be a lag time between the time of her retirement and the knowledge of who will fill her position.

An APPR Survey is being sent to superintendents for input on how the process can be changed for the better. They will have input on what should be included and how various components will be weighted.

PORTFOLIO PROJECT

Brief update from Christine Attlesey-Steger, Portfolio Project Chair

NYSATA Portfolio Project has officially begun in Regions 2 and 5 and training in Lake Placid will be President's Day weekend. We are currently negotiating with Region 8. This means we have 7 out of 10 participating regions. Region 7 North established the adjudication date for May 5, 9-12:30 at Dutchess Community College this year.

ADVOCACY

A tip from Dr. Susan Lane, Advocacy Committee Chair

Stay informed of the latest developments that affect arts education by adding these organizations to your Twitter feed:

- NYSATA (nysARTEach)
- NAEA (@NAEA)
- Americans for the Arts (@Americans4Arts)
- The National Assembly of State Arts Agencies (@NASAA_Arts)
- New Your State Education Department (@NYSEDNews)



Our Youth Art Month chairs and committee have been busy planning our biggest and best YAM celebration to date!

We are kicking off 2018 with our newest event **#MakeArtMonday!** Mark March 5th on your calendar now, and plan an event to showcase the value of creative endeavors in your school or community. It can be as simple as students working on a project in your classroom, an after school event for students (or your faculty), an “Arts Night” in your district, or a workshop at a local gallery or arts center. Capture creativity in action and share out on social media (Facebook and Twitter) using our hashtag! We would love to see a startup number of 100 events across the state! Register NOW at: https://docs.google.com/forms/d/e/1FAIpQLSck_3mLYthgp-Wk8oxW3UyEIXPwcz-z-iBepcnh0VGED-6Eg/viewform

Our 2018 Flag Design contest has had over 200 entries this year, an all-time record! Watch for the announcement soon, on social media, of our Grand Prize Winner whose design will be made into the State Flag, and our Division winners at High School, Middle School and Elementary Levels. Once again, prizes are generously underwritten by Sargent Art Company. Competition is strong, with an outstanding entry pool of well-crafted designs this year, using our theme Building Community Through Art.

Don't forget to participate in our flagship art event, The Legislative Art Show! More details are available at <http://www.nysata.org/legislative-exhibit> This is a well - attended event in Albany by our legislators, and the perfect chance to be an advocate for the visual arts!

Share with us, on our Facebook and Twitter feed, your YAM events! Show us what you are doing to demonstrate our theme of building community! We are amazed at the growth of participation and magnitude of shows and exhibitions across New York State, and new promotions! Be a part of our national award winning program, and a state that is looked upon as a leader in grassroots art advocacy across the country!

Facebook Page: <https://www.facebook.com/YouthArtMonthNewYorkState/>

Twitter Feed: YAM_newyork@youthARTmonthNY

If you need inspiration – be sure to check our weekly posts at the Artful Advocate Blog (<http://artfuladvocate.blogspot.com/>) Thanks to Phyllis Brown, our blogger extraordinaire who makes sure you will find inspiring and fresh ideas from our committee members. Check too, our **Uniting Community Full Circle Through Art** Lesson Plan written by Heather McCutcheon, at this link <https://nysata.memberclicks.net/assets/documents/YAM/YAM%202017.pdf> Heather is also our Social Media manager – who makes sure the word it out for all to see.

Finally, a big thank you to all who stopped by our YAM booth or attended our workshop at Conference this past November. It was great to talk to you, and share out how you can create a YAM event easily in your school.

If you were lucky enough to win a YAM t shirt –wear it with pride! Thanks also to Janice Wiggins, who helped man our booth, Julia Lang Shapiro who handles our Flag Design Contest, and Donnalyn Shuster who assembles our annual National Report and writes for the Artful Advocate!

We have our winners in our NYSATA 2018 YAM Flag Design Contest!

This year we had a record number of entries for the contest and making the selections was very difficult because there were so many wonderful entries!

The overall winner will have their work made into the flag that will hang at the NAEA Conference in Seattle in March. The overall winner will receive a smaller version of the flag to keep and display.

The elementary, middle and high school winners will also receive prizes generously provided by Sargent Art. The Honorable Mention student will receive a special certificate of recognition from NYSATA.

We will feature all the winning designs in the YAM Museum at the NAEA conference.

Overall Flag Design Winner (see next page)

Ilysa Sirota
12th Grade
Smithtown East High School
Tim Needles, Teacher

High School Winner

Felicity Boncella
12th Grade
Herkimer Jr./Sr. High School
Heather McCutcheon, Teacher

Middle School Winner

Elise Pape
6th Grade
Clinton Middle School
Amy Pape, Teacher

Elementary Winner

Alessia Cardinale
5th Grade
East Lake Elementary
Patti Krakoff, Teacher

Honorable Mention

Ashleigh Manzella
Kindergarten,
East Lake Elementary
Patti Krakoff, Teacher

Check out our Facebook Page to see the winning designs: @ YouthArtMonthNewYorkState

Artfully yours,
YAM Co-Chairs
Julia Lang-Shapiro, Donnalyn Shuster & Heather McCutcheon



Winner: Overall Flag Design, Ilysa Sirota, Gr. 12

nysata PORTFOLIO PROJECT



The NYSATA Portfolio Project is an authentic assessment based on the work your students are already doing in your classroom. If you have never participated, make this the year that you do!

- It is an authentic learning experience;
- An assessment instrument; and
- A powerful advocacy opportunity!

The Portfolio Project is being offered this year in Regions 2, 4, 5, 6, 7, 9, and 10.

Need more information?
Contact Portfolio Project Chair
Christine Attlesey-Steger
attlestine@gmail.com

Student Scholarship Opportunities



Recognizing Student Excellence

*“Hanging” and “Abandoned” by Alex S. Atkinson recipient of the Zara B. Kimmey Scholarship Award, Northport High School, Northport-East Northport UFSD
Robin O’Neill, Art Teacher*

An important facet of NYSATA’s mission is to support students who wish to pursue higher education in the visual arts. NYSATA currently awards the following five scholarships each year.

The Zara B. Kimmey Scholarship (\$1000), named for a founding member of NYSATA, and **The Bill Milliken Scholarship** (\$500), named for a long-time representative of Binney and Smith, have enabled many students to help purchase supplies and supplement tuition. These one year awards were established in honor of two NYSATA members who provided exemplary service to the field of art education. Zara B. Kimmey was the founder of NYSATA and the first Art Education Associate in the New York State Education Department. Bill Milliken, a Vendors’ representative on the NYSATA board, encouraged generous support for art education from the manufacturers and distributors of art materials.

The Elaine Goldman and Aida Snow Scholarships (2 scholarships at \$500 each) were generously endowed by Ms. Snow and Ms. Goldman. Ms. Elaine Goldman is a retired Region 9 member who continues to participate at the regional level, and is a frequent presenter at the state conference. Regretfully Ms. Aida Snow has passed away, but she has left a legacy of enabling NYSATA to help visual art students in New York State pursue their dreams.

The Barry W. Hopkins Award (\$500) is our newest scholarship award, added in 2008. Barry Hopkins was a teacher of art in the Catskill Central School District for 37 years. He had a passion for teaching and for sharing his love of the Hudson River School of Art and the Catskill Mountains.

He was known for his connection to earth and nature, and he taught his students to honor and celebrate the natural world through their art. An active and contributing NYSATA member for many years, Barry gave endless numbers of workshops, chaired conferences, and contributed to and participated in the NYSATA Summer Institute since its inception. His positive influence in the art world lives on through the many lives he touched and will also continue through this scholarship.

These scholarships are open to any graduating senior who is a student of a NYSATA member, intends to pursue a career in visual arts, and has been accepted by an art school or college art program. The award is presented at the annual NYSATA conference in November of each year. Winning students and their parents or guardians are invited to the awards ceremony as guests of the Association. For students who cannot attend the ceremony, other arrangements are made for payment of the awards.

Scholarship winners are determined by a committee composed of NYSATA members from at least three different NYSATA regions. The Zara B. Kimmey scholarship of \$1000 will be awarded to the student in first place. Winners shall be determined based on their demonstration of commitment to the visual arts; development of a personal voice or vision; and evidence of mastery of the elements and principles of design in a range of media. An Application Form and Checklist of supporting material have been provided and may be copied as many times as needed. Please use both forms in making your submission. **The completed application, along with all required materials, must be postmarked by May 31 of each year.** Incomplete applications will not be considered. Notification of awards will be sent out by the end of June of each year.

NYSATA Annual Awards Nomination Information



Awards Chair Cindy Wells with Donnalyn Shuster, recipient of the 2017 Outstanding Service at the Time of Retirement Award

Call for Award Nominations

NYSATA rewards commitment to excellence in art education among members and supporters of the art education community with a series of awards that are presented annually at the state conference.

Regional Art Educator of the Year

Each of NYSATA's ten regions chooses one outstanding art educator to be awarded a plaque at the annual conference. Each region's nominee must be a NYSATA member in good standing. Criteria include outstanding contributions to the field of art education and service to the regional and state organization. **Region Chairs must sign and forward Region awardee materials to the State Awards Chair by May 15.**

Outstanding Service Award Retiree

Awarded at the time of retirement for outstanding service to NYSATA. Nominee must be an active or associate member for at least 15 years prior to retirement. Regions may choose to select a Regional awardee to honor within their region. Each Region may submit one candidate to the state awards committee for consideration for the State Outstanding Service Retiree Award, to be recognized at the annual conference. **Nominations are due to State Art Chair by May 15.**

Special Citations for Member, Non-Member, Institution, or School District Member

Awarded to a member, non-member, institution/corporation, or school district/university that has made a significant contribution to art education. Recipients are presented with a plaque at the annual conference. **Nominations are due to the State Award Chair by May 15.**

Please Note: Nominations for State, and Region Art Educator of the Year are due to the Region Chair by April 1, and must be forwarded to the State Award Chair by May 1st.

More information can be found by visiting the NYSATA website.

Grant Opportunity

A grant of \$500 is awarded annually to a NYSATA member to aid in the development of a specialized art education project or study that meets the criteria for this award. Qualifying projects must fall under one of the following categories:

Curriculum Development

- Development of instructional curriculum resources that will enhance student learning related to innovation, creativity, and critical thinking skills.
- Innovative curriculum design or development of units of study that enhance student learning through visual art.

Research

- Educational travel that results in the development of activities related to the instructional process, student learning, or student assessment.
- Advocacy or research projects that are intended to advance the field of visual art education.

Interdisciplinary or Multi-Cultural Teaching

- Individual projects that promote art education as an integral part of the curriculum and improve understanding across disciplines or cultures.

All proposals should demonstrate how this project benefits the individual and in turn, members of the art education profession. This award may not be granted to a NYSATA Region for any purpose.

About Raymond C. Henry

A graduate of Pratt Institute in 1929, Raymond C. Henry received certification for a permanent teacher's license from the State College for Teachers and a Bachelor's

and Master's Degree in Education from the New York University School of Education. He taught for 39 years. His career included teaching at Vincentian High School in Albany, the Schenectady City Schools, and Waterford High School, where he became art supervisor. Other teaching contributions included work at The College of Saint Rose in Albany, art classes for children at the Troy YMCA, and courses for adults at Russell Sage College.

The Raymond C. Henry Award of \$500 was established at the 35th annual NYSATA conference to honor Mr. Henry for the following achievements: being a founding member of NYSATA, his life-long tenure as NYSATA treasurer and instatement as Treasurer Emeritus, his life-long interest in art education, and his artistic contributions.

A check for the grant will be presented to the awardee at the annual state conference. Notification must be sent to the Awards and Honors Chair upon completion of the grant project.

The recipient of this award must share their grant project with the NYSATA membership either through the presentation of a workshop at the annual conference or through an article for the NYSATA News.

All application materials for the Ray Henry Award are due to State Awards Chair by May 15.

The State Art Educator of the Year Award

Nominations are open to any individual members who meet the specific criteria for this most prestigious award. Region awardees must be nominated separately for this award.

Candidates for nomination must be members in good standing who have demonstrated commitment and dedication to the field of art education and to NYSATA over an extended period of years. These individuals must have practiced exemplary teaching, strong advocacy, and have made an impact on those around them, both in their schools and in the organization.

Through their devotion, compassion and helpfulness to students and colleagues, they exemplify what it means to be the *New York State Art Educator of the Year*. Specific criteria for this esteemed award will be listed on the NYSATA website. **Nominations for this award are due to the State Awards Chair by May 15.** The recipient of this award will be recognized by NAEA at their yearly conference.



Submit your workshop proposal by the April 15th deadline and be entered in a drawing for two free conference registrations. Click on this link to submit your proposal:

[Click to go to the 2018 Workshop Proposal Form](#)



70th Anniversary **NYSATA** Conference November 16-18, 2018 Adam's Mark Hotel Buffalo, NY

As NYSATA celebrates its 70th Anniversary State Conference it is a time to reflect on the past and look to the contemporary practices that are transforming our profession and to meeting the needs of students in the 21st century. Transformation is about change, reconstructing, reinterpreting and translating what is, into something new and innovative. Artists are consistently pushing the boundaries of what it means to be an artist and what we call art. The newly adopted New York State Visual Art Standards have raised the bar and challenged all of us to transform our educational practice.

NYSATA invites you to consider sharing what you are doing to:

- Construct an environment of inquiry through exploration and experience with traditional and contemporary art practices?
- Provide opportunities for students to create transformative works of art that present opportunities for personal artistic choice and focus on imagining, investigating, constructing, and reflecting?
- Foster collaboration with artists in the community in order to create media works that utilize technological innovations?
- Communicate and collaborate with stakeholders, policymakers, institutions, businesses, and industries
- to advocate for the whole child?
- Use artistic investigation in the classroom, the school, or wider community to transform current practice and pedagogy?
- Create learning communities among students, educators, or non-educators?
- Highlight student achievement or pedagogy that is changing schools, local communities, or the world?
- Integrate the newly adopted NYS Standards and how you are adapting your curriculum to meet these new standards.

Don't think you have enough expertise to present? Helping other teachers learn allows them to build a better future of the profession. Your efforts toward sharing quality information make this process of growth possible and improves the lives of everyone. Success isn't just about what you accomplish in your life. It's about what you inspire others to do. Please consider taking this opportunity to inspire others and give back to your profession.



SUNY Buffalo State's art education program, established in 1930, is among the oldest and most prestigious state-sponsored preparatory programs for art teachers in the United States. Our students learn the theory and practice of teaching art in pre-K-12 settings while gaining depth of knowledge as thoughtful reflective artists. Our B.F.A program combines pedagogy, contemporary art theory, and in-depth studio practice to prepare our graduates to be artist-educators in schools and art settings in the U.S. and around the world. The goal is to encourage our graduates to engage minds through making and teaching art in all its complexity.

- > Bachelor of Fine Arts in Art Education
- > Postbaccalaureate Certification in Art Education
- > Master of Science in Art Education

Alice C. Pennisi, Ed.D., Program Coordinator
pennisac@buffalostate.edu (716) 878-4106
arteducation.buffalostate.edu
 Facebook: Buffalo State Art Education

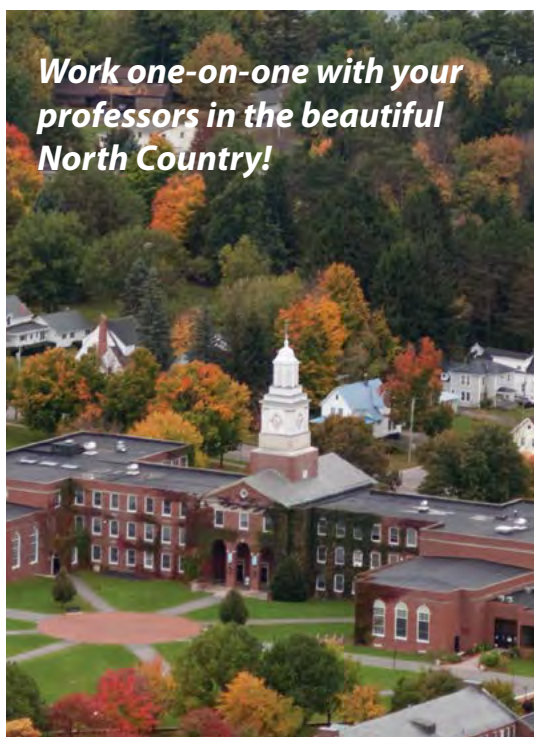

Work one-on-one with your professors in the beautiful North Country!

SUNY POTSDAM ART DEPARTMENT

B.A. and B.F.A. degrees in Art Studio and Graphic Design and New Media
B.A. degree in Art History
Concentrations in Ceramics, Painting, Photography, Printmaking, Sculpture
 Art Education Certification Program Pre-K-12
Minors include Museum Studies, Pre-Creative Arts Therapy, Journalism, Film Studies



To learn more about our programs, or to set up a campus visit, call (877) POTSDAM or direct at (315) 267-2180 or email: admissions@potsdam.edu.



Robert Wood with Cindy Henry and his daughters Sarah and Emily.

Robert Wood's Acceptance Speech

As Colin Firth said to the Academy in his acceptance speech as Best Actor for *The King's Speech*, "I think my career just peaked." If you've never seen *The King's Speech* please do so. One of the best visually composed films ever made, not to mention the best wall in motion picture history. To be a recipient of this recognition, following the likes of Jen Childress and Cindy Henry, is rather puzzling to me. I have pondered and would like to say a few words: service, self-doubt, challenges, and rewards. In a roundabout way, as sometimes in a film, the message may be in the sum of the parts. I hope the takeaway will be personal.

In the fall of 2013 at the Hilton in Albany, I was sitting alone, manning the Portfolio Project booth in the back of the vendor area, when I was approached by Jane Berzner and Jessica Bayer. After a brief conversation about Portfolio, Jessica looked at me and asked me to consider running for President of NYSATA. My immediate reply to her was, "I'm not smart enough." In my conversations to other members of the BOT, I discovered I was not alone in that sentiment: a shared feeling, perhaps a hesitancy to serve.

On our first day of Team East Conference in Baltimore this past summer (Team is the semi-annual meeting of state Arts leadership in the northeast US of NAEA), we broke out into groups of three or four where we intimately revealed life challenges faced in our journey to this point. When finished, we summarized each others challenges, and the subsequent strengths that fueled conquering those challenges. One leader spoke of overcoming her challenge of being deaf. Labeled in

her childhood as retarded, she fought her way out of that classification to a career as a successful art educator and leader in her state. Another leader spoke of: the struggles within her family: setbacks; a paralyzing public-speaking phobia; embracing opportunity; support and encouragement from her peers. After I told my story, my fellows in the group looked at me and said, "your challenges are within yourself."

A few years ago, Daniel Pink delivered the commencement address to the 2008 class of the Minneapolis College of Art and Design. I highly recommend viewing it, and if you are a secondary teacher, showing it in your classroom. In his, "It's Not About You, There Is No Plan, Persistence Trumps Talent" speech, he recalled the story of



Robert Wood accepts his award

former speech writer for President Reagan, Peggy Noonan. One of her many prolific speeches included Reagan's address to the nation following the Challenger explosion. Daniel Pink recalls her once saying, "When I got to the White House, I kept saying to myself, I hope no one discovers how dumb I am." After awhile serving, saying, "Hey, I'm as smart as everyone here," which was soon followed with, "Oh my goodness, we are in charge?"

I suppose we all have moments or phases of self-doubt, whether acknowledged or deeply buried. Acknowledge them. Embrace them. Laugh at them. They may continue, but eventually will be less significant and begin to serve as a catalyst to continue the good work we do. Our world is better off when we acknowledge our mutual struggles of self. A funny anecdote following Team East: when I returned home, my daughters joined me for a dinner at a Chinese restaurant down by the river. I opened my fortune cookie to read this: "Leadership is action not position."

So why do we do this? Because it is not a career it is a vocation; it is a calling; a deeply personal feeling we have to do this. We will succeed simply because of our love of this profession, this vocation, as we continue to be inspired, driven, motivated, nourished. While we may be intimidated by the new tools and materials such as those in Media Arts, the love of what we do will conquer any fears of worrying if we can do it. I have yet to meet someone who was intimidated by new technologies and tried new technologies, who is not enjoying using them today!

Young teachers following a love of art, to retirees, dedicated to continuing a passion, do so not as a career, but as a vocation: as a calling. We come to this vocation with good intent, with a focused skill to foster authentic engagement, imagination, and the responsible communication of what is significant in our immediate society. . . and our society is in dire need to be transformed by the Arts. Following the Las Vegas shooting, Country music singer Eric Church, when asked about his return to the stage so soon after the tragedy, said this regarding his art, "Music is the only way I know how to fix anything." Two weeks ago, our school faced a tragedy. A pickup with four students lost control, rolled and ejected two of the students. One student lost his life. The next day, our library was filled with students wearing his favorite color, supplied with art materials. Making. Processing. Above and beyond data collection; beyond Creating, Producing, Responding, and Connecting, the arts serve a deeper human need. They heal.

In February of every year, my school has a freshman orientation where parents are introduced to the course options for their child's first year. Before the event, I was having a conversation with a music colleague, Matt, where we shared absurdities in education. "Matt," I said, "34 years ago, as I was beginning my vocation, the call from Drew Mills, Roger Hyndman, and National was, 'Defend the arts,

defend the arts, defend the arts.'" Here we are 34 years later, still defending the arts, defending the arts, defending the arts' Matt looked at me and smiled, "We're still here . . .".

It's a perpetual cycle. We are in an amazing time for the Arts. New Standards, a new fifth discipline in Media Arts, significant steps forward in fostering artistic behavior, communication, connection with career and society. Our call and need for service, however, is needed more than ever. Ignorance continues to exist with building, district, state, and national leaders, even some at the State level in education; new generations of leadership who still don't get it, perhaps pulled down by bureaucracy, perhaps not able to compartmentalize the benefits of Arts education. Back to the Peggy Noonan quote: we are in charge. The responsibility to continue to fight this fight, to lead this cause, is on the shoulders of the people in this organization. You will be the ones that will lead, through presenting, informing, and engaging.

We do have an amazing organization. This is no big machine. We are volunteers. We can be weakened by complacency and strengthened by newness and enthusiasm, fostered by experience and wisdom. Veteran leadership leads by example. New leadership breathes life. Together, we support each other.

The takeaways? We contribute our talents, discover and develop strengths in new areas, bettering ourselves, and bettering our profession. We pass these strengths to our peers. Others from around the country look to the strength of NYSATA for guidance and for leadership. Last year, at a reception preceding the President's Dinner, Dennis Inhulsen, NAEA Chief Learning Officer, in conversation, paid NYSATA a beautiful compliment. "When you see your membership enjoying themselves, wanting to be together, it's a sign of a healthy organization".

Thank you to this organization. The opportunity to network and form bonds with state and national leadership

has been immeasurable. My takeaway has been more than my contribution. Thank you, NYSATA BOT. You have supported

So why do we do this? Because it is not a career it is a vocation; it is a calling; a deeply personal feeling we have to do this. We will succeed simply because of our love of this profession, this vocation, as we continue to be inspired, driven, motivated, nourished.



Robert Wood with Cindy Henry

me and, at times, carried me. It has been an honor to work and serve with you.

Thank you, Diane Knapp, whose love of the Portfolio Project brought me into the family of NYSATA.

Thank you, Pat Groves. When I was at a crossroads in my personal life, you mentored and assured me I will be supported.

Thank you Region 7. Your leadership over the years from Kelley, Marty, Sharon, and Amanda exemplify the qualities that continue to move our profession forward.

Thank you to Leslie Yolen, who not only has defended, but has led the Arts from her small cubicle at the State Education Department (one person working for us at State Ed., folks). She recognized the talents and insight of NYSATA and the other professional organizations and reached out to them to create the best set of Arts standards in our State history. We have a responsibility to inform the leadership at the State Education Department Arts education must continue to be supported.

Thank you to the Wappingers Art Department: Principals Tom Stella, David Seipp, Superintendent Jose Carrion, Assistant Superintendent Dr. Cardwell, Bob Jutton, and Lori Orestano James. From faculty to administration, you get it. You understand the personal, societal, and economical benefits of Arts education. You understand that it is much more than the original and continuous maker space; that the Arts transcend the imaginary confines of disciplines. Your leadership exemplifies how sequential K-12 Art education should run in New York State.

Thank you, Gina Palmer. You are my other big sister and an inspiration.

Thank you to my students for fueling me with your love of creating, producing, responding, and connecting. It has been a joy to watch you move on to exciting careers, knowing your love began in the art rooms of our district. From working in the White House, to working in television, film, and even

in art education, I am proud of you. I am thankful for you making me a better teacher.

Thank you Robert Zackarian, from Pratt Institute, for supporting my personal path of utilizing performance, sounds and electronic media as tools of communication.

Thank you to Robert Cartmell and the late Edward Cowley from SUNY Albany. Thank you Roger Hyndman, who as department chair at Shaker High School fostered my outstanding Art education. Thank you to my middle and high school art teachers: Lee Northup, Elizabeth Lee, and Jane Feldblum.

Thank you to my parents. To my Mother, 87, who has demonstrated a life of service, selflessness, hard work, servitude. Thank you to my Father, 94, who from the beginning of my life, fostered a love of the arts and the wonder and beauty of this world. Making my first crayon box for first grade (I still have it), taking me to museums around the northeast, trusting me with his Bell and Howell and Nizo-Braun 8mm movie cameras and editing equipment to make films as an elementary school child, introducing me to the amazing history of radio and film, and ultimately being there to connect to and share in the arts as adults.

Thank you to my two girls, Sarah and Emily; both pursuing a calling service. Emily is a junior majoring in Psychology at SUNY Oneonta. Sarah is a junior at Rhinebeck High School preparing for her second Interact trip to Nicaragua. I love you completely. You haven't seen a great deal of traditional art making from me, but I hope I have provided the support and inspiration through the new thinking in art, video productions, and the artistic work in our daily life.

Thank you to Cindy. My first encounter with you was filled with the overwhelming thought that I had better have my act together to work with you. I still carry that thought. You are the best gift I could have ever received from NYSATA.

I am extremely humbled by this recognition. The opportunity to serve along side of you is an honor. I am in awe of the amazing things you do because of your love of this profession and I share this with you. Each day we make a difference. May God bless all of you and may this organization continue to support your journey in this vocation as much as it has supported mine. Thank you.

We are in an amazing time for the Arts. New Standards, a new fifth discipline in Media Arts, significant steps forward in fostering artistic behavior, communication, connection with career and society.

2017 NYSATA Conference Highlights

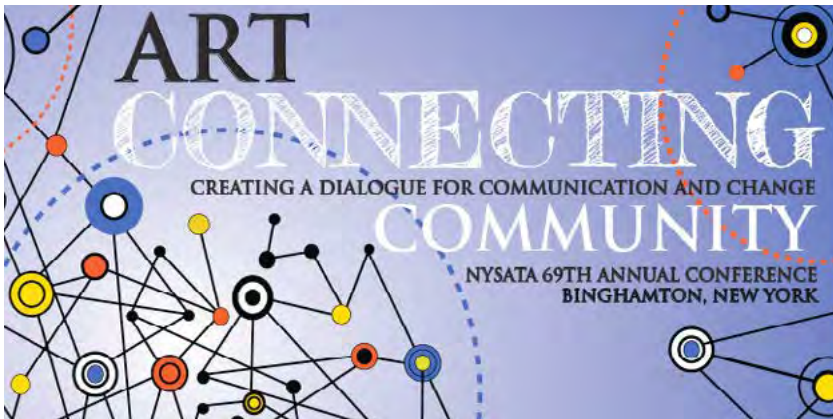

...at the 69th Annual NYSATA Conference

Amazing Keynote Speakers



Dr. Julia Marshall



Nick Cave



Rachel Branham



Dr. Jessica Fridrich

A community who embraces ideas . . .



A community that embraces change . . .



**NYSATA
Pre-Conference
Rising to
New Standards in
Art Education**



... and values life-long learning



A community of colleagues and friends...



. . . and future art educators



A community willing to work together . . .

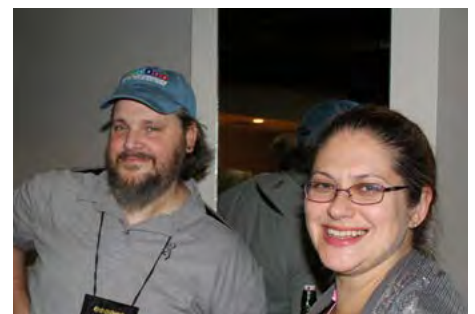

... so that special moments can be shared



A community that honors hard work . . .



(R-L) Lauren Lewonka, Albert Justiniano, Christopher Lissandrello, Veronica Kruger, Monica Schor, Jodi Wilmarth, Janice Wiggins, Barbara Hirten, Patricia Testo

2017 Region Art Educators of the Year



Special Citation Institution: The Wellin Museum of Art



Outstanding Service at Retirement: Donnalyn Shuster



Ray Henry Award: Terry Lindsay-Barton

... and dedication to teaching





1

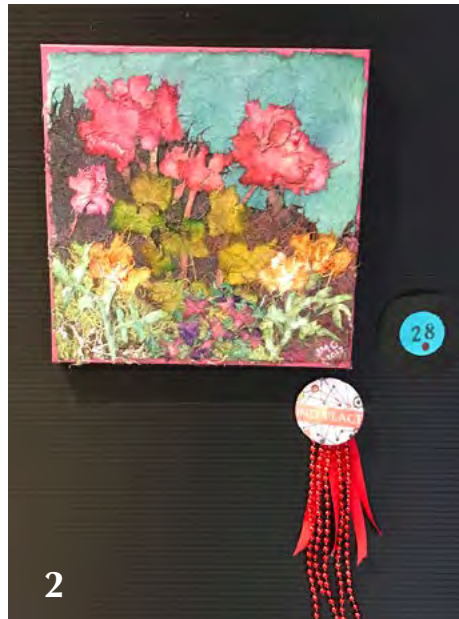

2

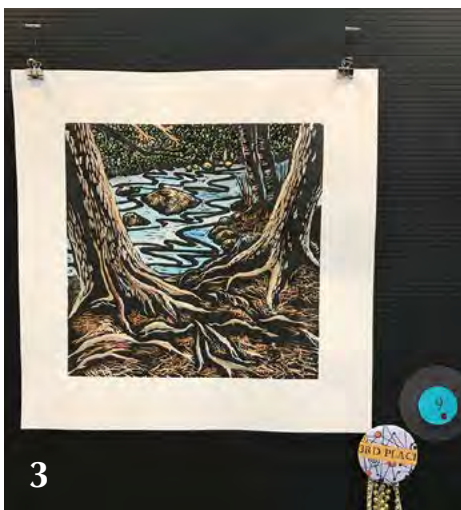

3



4



5

2017 10X10 Member Exhibit

The 2017 Members Exhibit at the annual NYSATA was a hit this year. The exhibit had a different format. Our members were asked to create a piece of art 10" x 10" (symbolizing our 10 regions of NYSATA). There was no entry fee and all the pieces submitted were for sale, proceeds going to the NYSATA Student Scholarship fund. Each piece was sold for \$20, a bargain for sure.

The work submitted was outstanding. Artists who didn't want to part with their piece could pre-purchase their own back before the sale opened. The exhibit was juried as usual for 1st, 2nd, and 3rd place, Honorable Mention as well as the People's Choice Award.

The proceeds from the sale of the art work generated \$2,272.00 for the scholarship fund.

Winning Entries:

- [1] 1st Place Jen LaCava, watercolor painting
- [2] 2nd Place Jen Mattot, mixed media
- [3] 3rd place Beth Atkinson, woodcut
- [4] Honorable Mention Mary Brodersen, fabric collage
- [5] People's Choice Award, Beth Atkinson for her assemblage sculpture

NYSATA Board of Trustees

OFFICERS

PRESIDENT
Sharon Ciccone
sharon.ciccone@sufsdny.org

VICE-PRESIDENT
Donnalyn Shuster
d_shuster@yahoo.com

SECRETARY
Anastasia Arriaga
aarriag7@naz.edu

TREASURER
Valerie Savage
treasurer@nysata.org

PAST PRESIDENT
Robert Wood
rwood@nysata.org

BOT & COMMITTEES
REGION 1 CO-CHAIR/REP, SAGAMORE INSTITUTE CO-CHAIR
Michelle Schroeder
sodrawme623@roadrunner.com

REGION 1 CO-CHAIR/REP ELECTIONS CHAIR
Jan Dylewski
jdylewski@buffaloschools.org

REGION 2 CO-CHAIRS
Alyssa Lindstrom REP
alyssa.lindstrom@gmail.com

Tess Hanna
region2cochairs@gmail.com

REGION 2 REP
Janice Wiggins
janice.wiggins@greece.k12.ny.us

REGION 3 CHAIR/REP
Heather McCutcheon
nysata3@gmail.com

REGION 3 REP
Cynthia Wells
cynthia296@aol.com

REGION 4 CO-CHAIRS/REPS
Jill Karen Accordino
jkaccordino@yahoo.com

Geraldine Link
gmslink2002@yahoo.com

REGION 5 CHAIR/REP
Shannon Piche-Smith
pichsmith@charter.net

REGION 5 REP
Terry Crowningshield
tcrowningshield@elcsd.org

REGION 6 CHAIR/REP STEAM CHAIR
Kathleen Bushek
kbushek@ffcsd.org

REGION 6 REP
Phyllis Brown
plbrown3@yahoo.com

REGION 7 CHAIR/REP
Martin Merchant
merchantmartin@gmail.com

REGION 7 REP
Kelley Hedin
Kelley.hedin@wcsdny.org

REGION 8 CHAIR/REPS
Jill Cannon
artzspirit@gmail.com

Pearl Lau
pearllau@aol.com

REGION 9 CO-CHAIR/REP
Jessica Bayer
jsbayer23@gmail.com

REGION 9 CO-CHAIR/REP
Jane Berzner
ARTTEACH@aol.com

REGION 10 CO-CHAIR/REP
Cheryl Schweider
cschweider@babylonufsd.org

REGION 10 COCHAIR/REP, STU SCHOLAR CH.
Lori Corbisiero
lcorbisiero@sachem.edu

LEGISLATIVE EXHIBIT
Carol Pinkans
carol.pinkans@gmail.com

PRE-SERVICE COLLEGE LIAISON
Dr. Mary Wolf
mwolf@daemen.edu

PRE-SERVICE STU. REPS
Nazareth College
Chloe Dudla
cdudla9@mail.naz.edu

Erin Maloney
emalone3@mail.naz.edu

PORTFOLIO PROJECT CHAIR
Christine Attlesy Steger
attlestine@gmail.com

NYSCEA REP
Sheila Elario
elarrios@guilderlandschools.net

Dr. Patricia Wheelhouse
Patricia.wheelhouse@gmail.com

OLYMPICS OF THE VISUAL ARTS
Roger E. Hyndman
ova@nysata.org

SAGAMORE INSTITUTE CO-CHAIR
Beth Atkinson
bethatkinson12@hotmail.com

NYSATA NEWS EDITOR
Martin Merchant
nysatanews@nysata.org

PROMOTIONS CHAIR CONFERENCE COOR. NYSATA NEWS LAYOUT
Patricia Groves
phgroves@aol.com

CONFERENCE COOR. AWARDS & HONORS
Cynthia Wells
cynthia296@aol.com

YAM CO-CHAIRS
Donnalyn Shuster
d_shuster@yahoo.com

Julia Lang-Shapiro
eyecre8art@yahoo.com

Heather McCutcheon
nysata3@gmail.com

NYSED ASSOCIATE
Leslie Yolen
Leslie.Yolen@nysed.gov

WEBSITE COOR. DISTRICT MEMBERSHIP
Cindy Henry
website@nysata.org

DISTRICT MEMBERSHIP
Regina Russo
iheartart529@gmail.com

NYSBBA EXHIBIT CH.
TBD

LEGISLATIVE EXHIBIT
Carol Pinkans
carol.pinkans@gmail.com

BOT SUNSHINE CHAIR
Zita Rosen
zita31845@yahoo.com

ADVOCACY CHAIR
Dr. Susan Lane
sue.lane@clydesavannah.org

CONTRACTED POSITIONS

MEMBERSHIP ACCOUNTS RECEIVABLE CONF. REGISTRAR
Terri Konu
tkonu@nysata.org

FINANCIAL ADVISOR ACCOUNTS PAYABLE
Leslie Midgley
LRMINC@nycap.rr.com

NYSATA Region Counties

| Region | Region Name | Counties Included in Each Region |
|--------|-----------------|--|
| 1 | Western | Cattaraugus, Chautauqua, Erie, Genesee, Niagara, Orleans, Wyoming |
| 2 | Finger Lakes | Allegany, Livingston, Monroe, Ontario, Wayne, Seneca, Steuben, Yates |
| 3 | Central | Cayuga, Herkimer, Jefferson, Lewis, Madison, Oneida, Onondaga, Oswego, St. Lawrence |
| 4 | Southern | Broome, Chemung, Chenango, Cortland, Delaware, Otsego, Schuyler, Tioga, Tompkins |
| 5 | Adirondack | Clinton, Essex, Franklin, Hamilton |
| 6 | Capital Eastern | Schoharie, Albany, Columbia, Fulton, Greene, Montgomery, Rensselaer, Saratoga, Schenectady, Warren, Washington |
| 7 | Southeastern | Dutchess, Orange, Putnam, Rockland, Sullivan, Ulster, Westchester |
| 8 | NYCATA/UFT | Bronx, Brooklyn, Manhattan, Queens, Richmond |
| 9 | LIATA-Nassau | Nassau |
| 10 | LIATA-Suffolk | Suffolk |